

Rack Puller for Diesel Engines Model RP75



Features

- Pulls Injection Pump or Air Intake Shut-off Lever
- 30 lbf (133 N) Operating Force
- Models Available for 12 or 24 Volt Systems
- Operates on Signal from SWICHGAGE® Installed on the Engine or Driven Equipment

The RP75 rack puller is a semi-automatic device that provides a pulling force to initiate shutdown of diesel engines and equipment.

The RP75 connects to the injection pump or air intake shut-off lever via a cable (chain optional). A coil spring, within the RP75, is reset manually and is held in place by an electromagnet. When the SWICHGAGE® detects a malfunction, the electromagnetic circuit is interrupted through a Magnetic Switch—releasing the coil spring thus pulling the cable/chain to actuate shutdown. The spring, when fully compressed, exerts a pull of 30 lbf (133 N).

The RP75 is available for 12 or 24 VDC applications and is compatible with all SWICHGAGE® instruments.

Specifications

Operating Force: 30 lbf (133 N) maximum, 10 lbf (44 N) minimum.

Coil Voltage: Specify 12 or 24 VDC.

Coil Resistance: RP75-12: 32.2 ohms. RP75-24: 129.8 ohms.

Length of Travel: 1-7/8 in. (48 mm).

Control Linkage

- Cable: 4ft. (1.22 m); Optional 8 ft. (2.43 m) or 12 ft. (3.65 m) available.
- Chain (optional): 30 in. (762 mm).

■ **NOTE: Specify options when ordering.**

Shipping Weight: 5 lbs 3 oz. (2.4 kg).

Shipping Dimensions: 9-1/4 x 8-1/4 x 5-1/4 in. (235 x 210 x 133 mm).

Dimensions

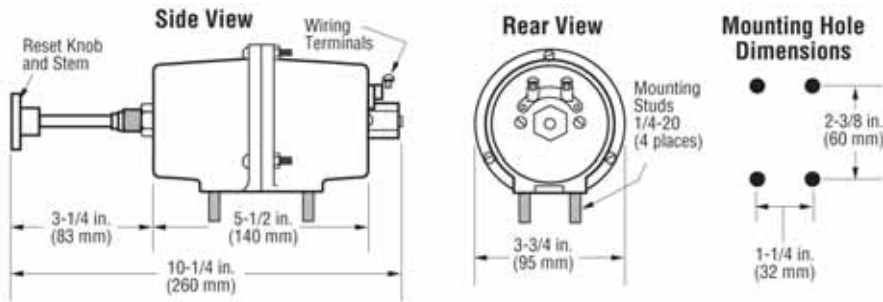

How to Order

Specify model number.

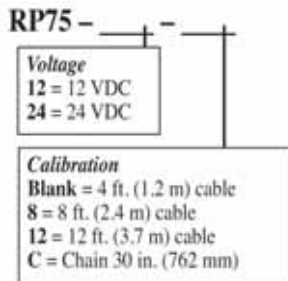

Mounting Bracket 40-05-0161 is sold separately. Specify part number when ordering.

Service Parts

Specify part number.

Part Number	Description
40-00-0021	12 VDC core assembly
40-00-0044	Shaft solenoid assembly
40-01-0050	Bushing shaft assembly
40-01-0053	Case repair kit
40-01-0054	Cocking rod, bushing and knob repair kit
40-05-0136	Spring, main actuating
40-05-0149	Spring, cocking rod return
80-04-1030	2 Screws, machined #10-24 x 3/8 pan HD steel CAD II
40-00-0024	24 VDC core assembly

Installation Instructions



WARNING Before beginning installation of this Murphy product:

- ✓ Disconnect ALL electrical power to the machine.
- ✓ Make sure the machine CANNOT operate during installation.
- ✓ Follow all safety warnings of the machine manufacturer.
- ✓ Read and follow all installation instructions.

Mounting

1. Mount the RP75 using the 40-05-0161 mounting bracket or similar (see **Figure 1**). If installing the RP75 to an engine compartment firewall, go to Step 2.
2. If installing the RP75 to an engine compartment firewall, drill a 37/64 in. (15 mm) diameter hole in the firewall (see **Figure 2**).



WARNING: The firewall must be capable of withstanding the push and pull force of the RP75.

3. Remove the reset knob on the RP75 by loosening the allenhead screw on the knob.
4. Remove the mounting nut and insert the RP75 reset stem through the hole from the back of the firewall.
5. Replace the mounting nut and tighten. Reinstall the reset knob.

Typical Wiring Diagrams

Wire the RP75 appropriately (see **Figure 3**).

NOTE: RP75 is voltage rated; do not apply 24 VDC to 12 VDC model and vice versa. Also, the 117PH Magnetic Switch is rated for both 12 and 24 VDC circuits but voltage must be specified when ordering the 518PH or 761APH Magnetic Switches.

Installing Cable or Chain

1. To install the control linkage (cable or chain), apply voltage to the RP75. Push in the reset knob. If installing the cable, insert the cable attaching nut into the RP75 and tighten snugly (see **Figure 1**). **DO NOT OVERTIGHTEN** or threads may strip. Attach and tighten outer cable securing nut. If installing the chain, attach the "S" hook to the RP75 (see **Figure 1**).
2. Attach the other end of the cable or chain to the injection pump or air intake shut-off lever so it moves freely without sharp bends and without binding.

Operation Test

NOTE: Some method must be provided to disconnect (lockout) all normally closed SWICHGAGE® circuits when starting (such as through the appropriate Magnetic Switch).

1. Reset magnetic switch.
2. Push in RP75 reset stem until coil latches the trip mechanism.
3. Start engine and observe that all locked out contacts clear.
4. With engine running, ground SWICHGAGE® contact. The Magnetic Switch will trip thus removing voltage to RP75. The engine should shutdown immediately. If the engine does shutdown, adjust control linkage (cable or chain) to ensure that shutoff lever travels the full length in both directions.



CAUTION: Shut-off lever should not pull hard against the stop in the "off" position.

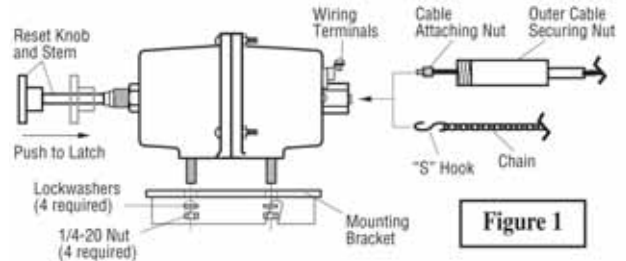

Figure 1

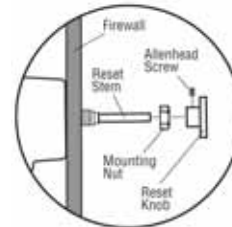

Figure 2

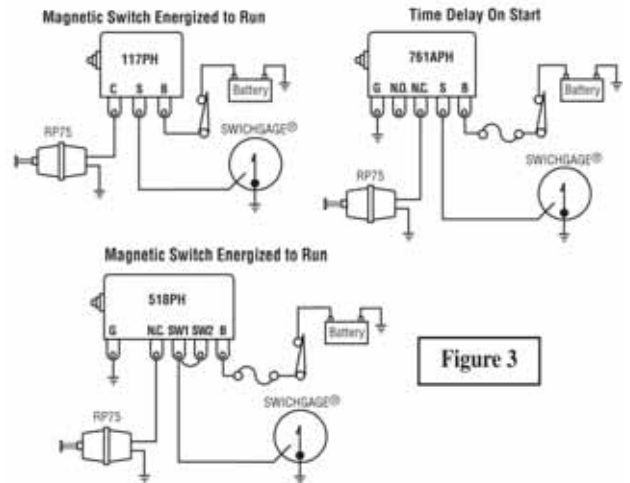

Figure 3

Warranty - A limited warranty on materials and workmanship is given with this FW Murphy product. A copy of the warranty may be viewed or printed by going to <http://www.fwmurphy.com/warranty>