

Electric Gage Shutdown Panels for DEUTZ 1011/2011, 912/913 and 914 – WDU Series Panels



Features

- Environmentally Sealed Electric Gages with LED Illumination Provide Accurate Readouts
- Reliable Shutdown Protection On Low Oil Pressure and High Engine Temperature
- Includes “Plug and Go” Package for Quick and Easy Installation to 1011/2011, 912/913 and 914 DEUTZ Engines
- Recessed Front Panel Design Houses Components and Utilizes a Hinged Front Cover for Easy Access to Internal Components
- Features Engine Preheat Circuit

Deutz engines that come factory equipped with electric-switched oil pressure and temperature senders can now be outfitted with a standard line of electric gage “Plug and Go” panels that take the work and time out of the installation process. Two bolts mount the panel to the engine’s bell housing and the included wiring allows for fast “Plug and Go” assembly. Simply remove two screws and the front hinged panel drops down allowing access to all the internal components. These panels are offered in three versions to accommodate all wiring and mounting requirements for DEUTZ 1011/2011, 912/913 & 914 Engines.

The panels are designed to compliment Deutz engines supplied with pre-installed factory-set “electric switched senders.” Protection against low oil pressure and high engine temperature is achieved with the Murphy 760A Time Delayed Magnetic Switch. A panel mounted 10 amp fuse protects the sensitive instrumentation from any over-current situation and stops the engine if blown. The Deutz pre-installed “electric switched senders” supply all shut-down signals directly to the Murphy 760A providing reliable and proven engine protection in harsh environments.

Critical engine information is provided with Murphy’s environmentally sealed; LED illuminated EG Series electric gages. Known for their reliable performance and constructed of corrosion resistive materials, these rugged gages exceed SAE J1810 standards for use in tough off-road and industrial power unit applications. A unique spin-on gage clamp keeps the gages tight even in high vibration applications. Murphy’s alternator driven ATHA 4000 RPM tachometer provides accurate display of engine speed with its back-lit dial, while the digital hour meter records the elapsed engine run time. The heavy duty key switch constructed of corrosion resistant materials and heavy gauge wiring exceed the current requirements of the starter and engine pre-heat circuit. A red lamp mounted on the front panel indicates when the pre-heat circuit is active.

All components are assembled into a robust black powder-coated enclosure with text indicating key position. The “Plug and Go” external wire harness connects to the rear of the panel and has all the engine side connections pre-wired. The panel mounting bracket comes pre-assembled to the enclosure with three vibration isolators, making installation fast and simple.

Features

- Oil Pressure Gage: 0-80 PSI (0-500 kPa)
- Engine Temperature Gage: 140-300 °F (60-150 °C)
- Volt Meter (8-18 VDC)
- Tachometer/Hourmeter (0-4000 RPM)
- Key Switch (Heavy Duty)
- Engine Preheat with Red Indicator Lamp
- Murphy 760A Safety Shutdown (Automatic Time Delayed for Start-up)
- Panel Mount Fuse
- Recessed and Protected Front Panel
- Durable Powder Coat Finished Enclosure and Mounting Bracket

Labor Saving Installation Features

- Pre-wired External Harness (Includes all connectors and terminals)
- Mating connectors match Deutz Engine wiring for fast “Plug and Go” connection
- Pre-assembled: Enclosure, Rubber Isolation Mounts and Mounting Bracket
- Simple Bolt-on/Plug-in Installation

WDU0814 Dimensions Includes Enclosure, Mounting Bracket and Shock Mounts

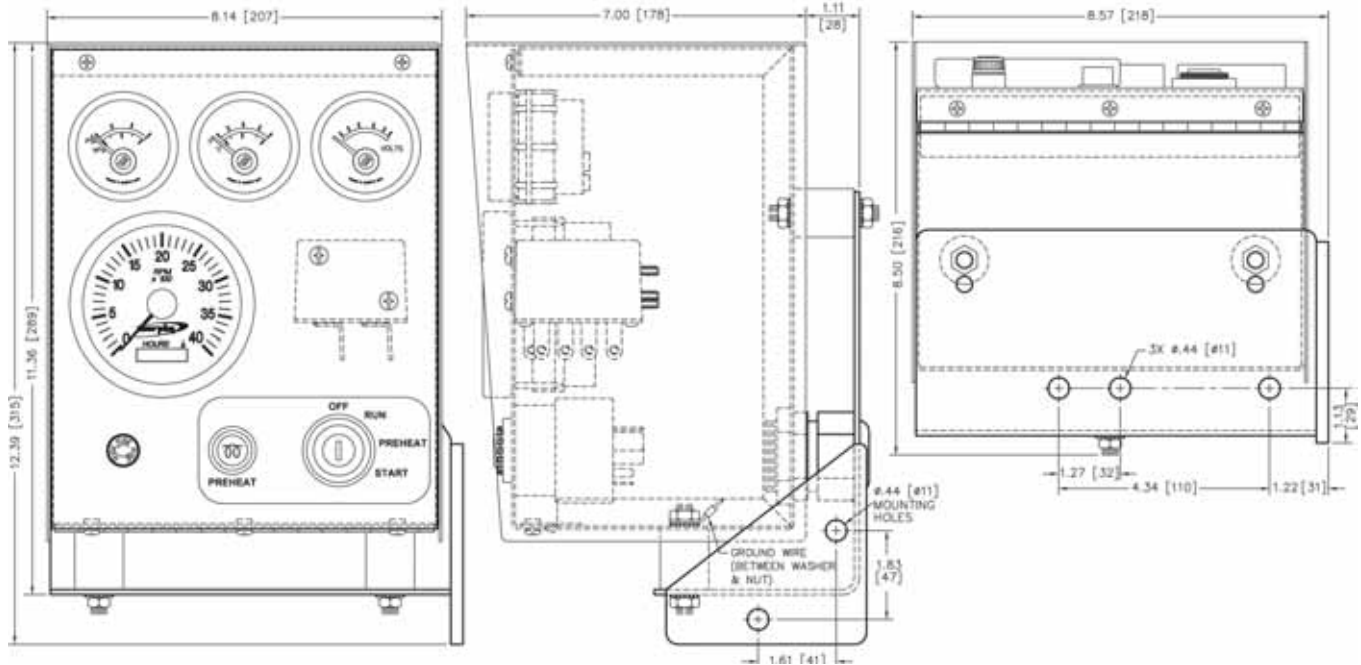

Wiring

NOTES:

- MURPHY HOOK-UP BOTH ENDS.
 - WIRE TO CUST GND TO EXTEND 36 INCHES FROM BACK OF PANEL.
 - WIRE TO CONN. STARTER, B+ TO EXTEND 42 INCHES FROM BACK OF PANEL.
 - TOLERANCE = $\pm 2^\circ$
 - APPLY SPLIT LOOM FROM BACK OF PANEL TO APPROXIMATELY 2 INCHES FROM END OF SHORTEST WIRE IN BUNDLE.
- WIRE TO GLOW PLUGS TO EXTEND 40 INCHES FROM BACK OF PANEL.
 - MARK OR TAG WIRES FOR CUSTOMER HOOKUP WITH NUMBERS OR LETTERS SHOWN.

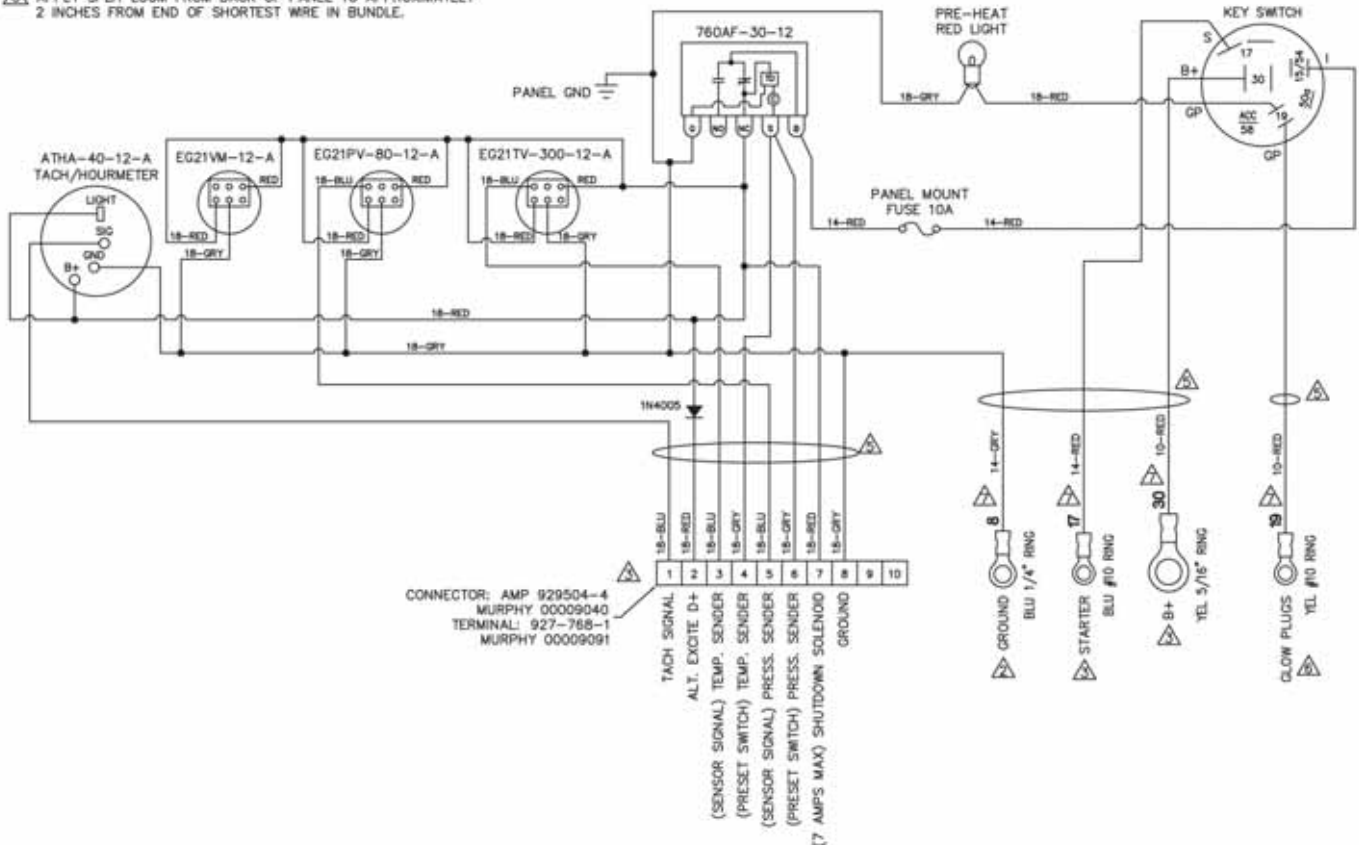

Warranty - A limited warranty on materials and workmanship is given with this FW Murphy product. A copy of the warranty may be viewed or printed by going to <http://www.fwmurphy.com/warranty>

WDU0815 Dimensions Includes Enclosure, Mounting Bracket and Shock Mounts

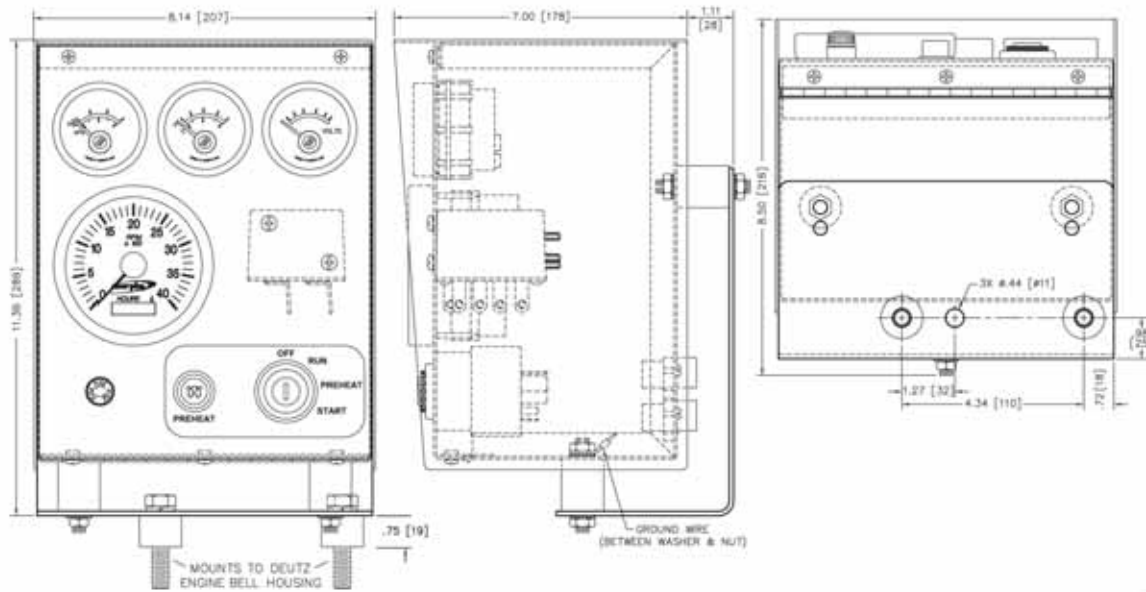

Wiring

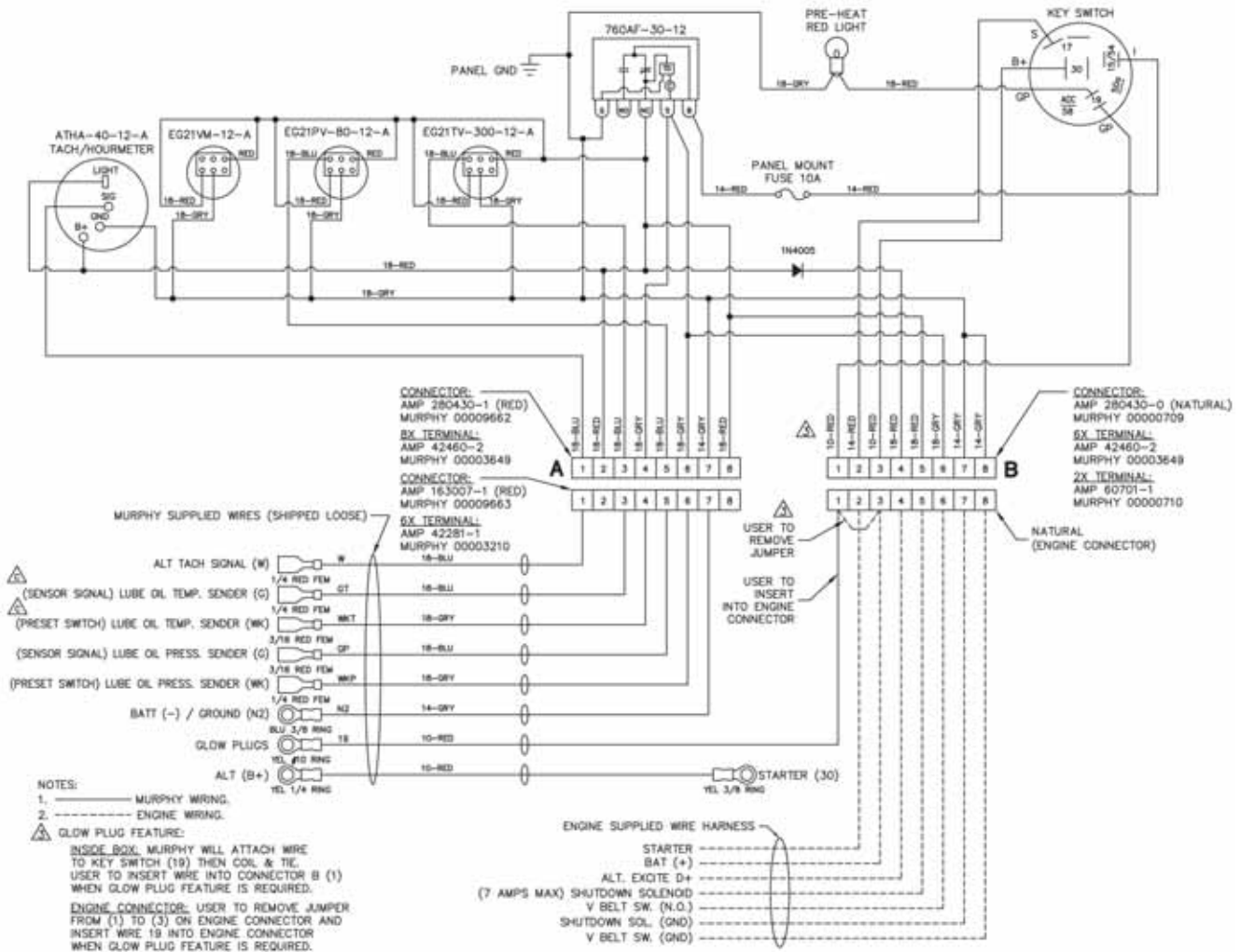

WDU0816 Dimensions Includes Enclosure, Mounting Bracket and Shock Mounts

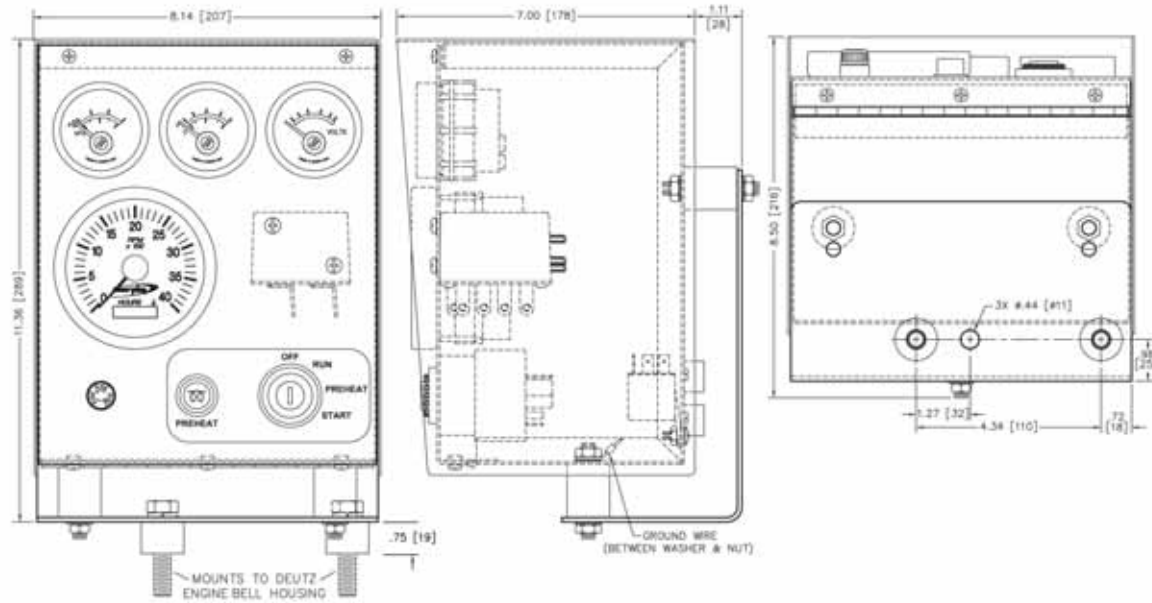

Wiring

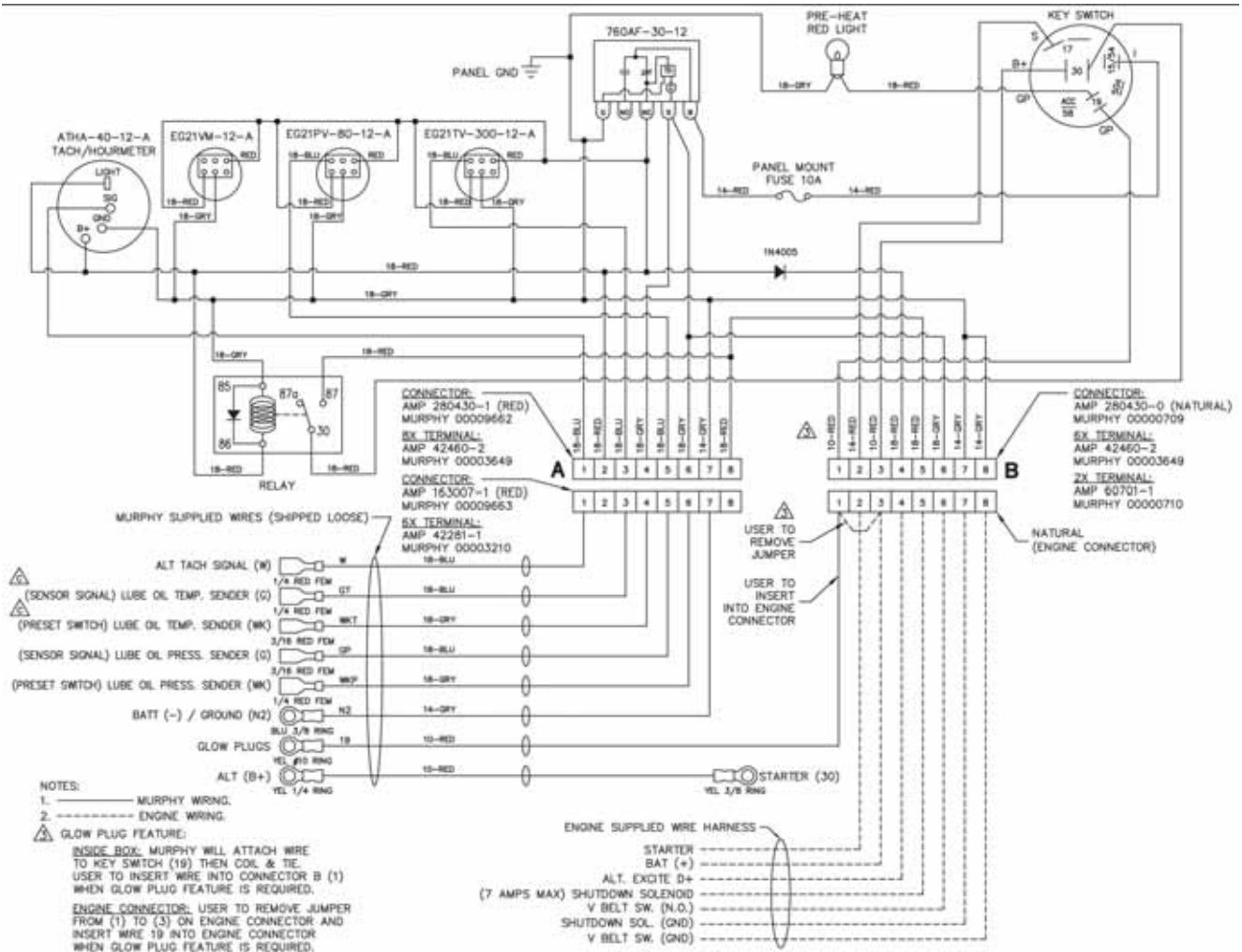

WDU0865 Wiring for Deutz 914 Tier 3 Engine Wiring

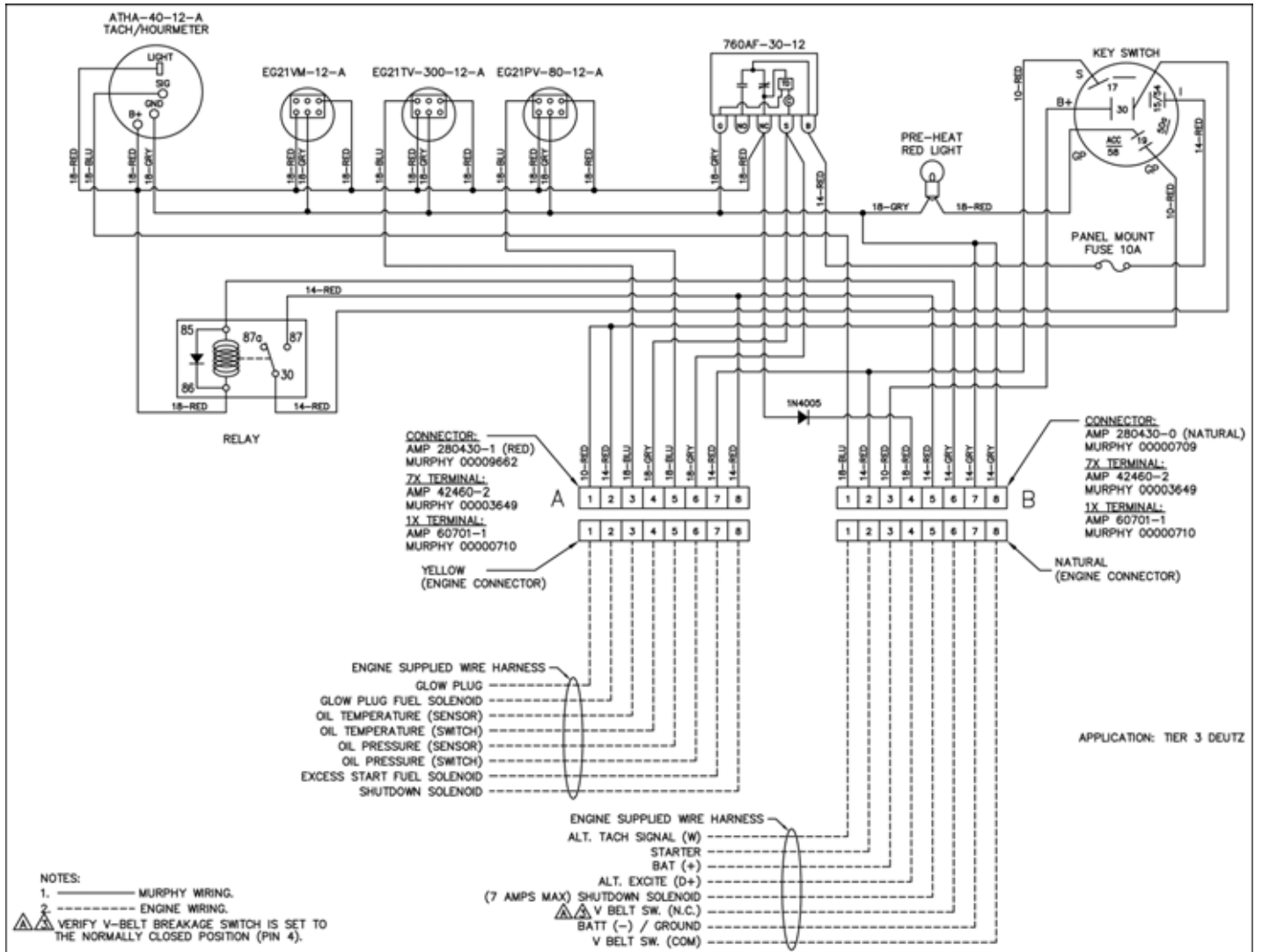

Specifications:

Voltage: 12 VDC.

Shipping Weight: 16 lb. (7.3 kg).

Shipping Dimensions: 14 x 15-3/4 x 9-1/2in. (356 x 400 x 242 mm).

WARNING: FLYBACK DIODE REQUIRED ACROSS ALL INDUCTIVE LOADS TO REDUCE THE POTENTIAL OF VOLTAGE SPIKES DAMAGING SOLID STATE COMPONENTS.

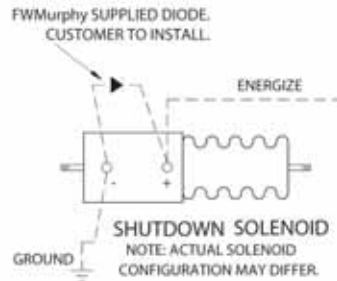

How to Order (Order your WDU panel using the model number)

WDU0814 Panel Number 30-70-0814 used on DEUTZ 1011/2011 Engine

- Includes Attached Wire Harness Pigtail with engine connector, battery (+), starter, pre-heat and ground wires.
- Mounting bracket has an additional plate to accommodate specific engine mount location

WDU0815 Panel Number 30-70-0815 used on DEUTZ 912/913 Engine

- Includes Loose External Wire Harness that plugs into back of panel, starter and pre-heat wires.
- Deutz supplied engine harness also plugs into back of panel

WDU0816 Panel Number 30-70-0816 used on DEUTZ 914 Engine

- Includes a relay housed internal to the panel for the fuel solenoid
- Includes Loose External Wire Harness that plugs into back of panel, starter and pre-heat wires.
- Deutz supplied engine harness also plugs into back of panel

WDU865 Panel Number 30-70-0865 used on Deutz 914 TIER 3 engines.

- Includes a relay housed internal to the panel for the fuel solenoid
- Includes Loose External Wire Harness that plugs into back of panel, starter and pre-heat wires.
- Deutz supplied engine harness also plugs into back of panel