

MurphyLink™ Series M310 Panels



Typical Application Shown,
Features Vary Per Engine
Application

Features

- Standard panel designed for modern electronic engines and equipment applications using SAE J1939 Controller Area Network (CAN)
- PowerView displays over 30 standard SAE J1939 parameters broadcast by major engine and transmission manufacturer's ECU's
- Display active faults and ECU-stored faults with text description on most common faults for diagnosing equipment malfunctions
- Standard harnesses available for most major engine manufacturers ECU's
- Enclosed design or flat panel option
- Deutsch connectors

The M310 Series Panels include the PowerView and the Mlink™ PowerView Analog Gages. They are part of the J1939 MurphyLink™ Family developed to meet the needs for instrumentation and control on electronically controlled engines communicating using the SAE J1939 Controller Area Network (CAN).

The PowerView is a multifunction tool that enables equipment operators to view many different engine or transmission parameters and service codes. The panels provide a window into modern electronic engines. The PowerView includes a graphical backlit LCD screen. It has excellent contrast and viewing from all angles. The display can show either a single parameter or a quadrant display for viewing four parameters simultaneously. Diagnostic capabilities include fault codes with text translation for the most common fault conditions.

The PowerView has four buttons using touch-sensitive technology, which eliminates the concern for push button wear and failure. In addition operators can navigate the display with ease. Enhanced alarm indication uses ultra bright alarm and shutdown LED's (amber and red). The PowerView has a wide operating temperature range of -40 to +85°C (-40 to 185°F), display viewing -29 to +75°C (-20 to 167°F), and environmental sealing to +/- 5 PSI.

Other components in the panels are microprocessor-based M-Link™ PowerView Analog Gages for displaying critical engine data broadcast by an electronic engine: engine RPM, oil pressure, coolant temperature, system voltage, etc. and an optional audible alarm and relay unit for warning and shutdown annunciation.

The M310 Series panels are available in an enclosure or stand-alone flat panel option that can be dropped into a dash or console. This standard panel can be ordered with or without an enclosure, since all of the components are assembled to a stand-a-lone flat panel. Optional mounting kits are offered for the enclosure, which provide packagers and operators numerous mounting solutions to meet multiple applications. Panel designs are offered to meet the needs of specific engine models. In addition, FWMurphy offers standard harnesses for quick Plug and Go operation that interface with all the MurphyLink™ PowerView panels.

Display Parameters

The following are some of the engine and transmission parameters displayed by the PowerView in English or Metric units (when applicable), consult engine or transmission manufacturer for SAE J1939 supported parameters.

- Engine RPM
- Engine Hours
- Machine Hours
- System Voltage
- % Engine Load at the Current RPM
- Coolant Temperature
- Oil Pressure
- Fuel Economy
- Throttle Position
- Engine Manifold Air Temperature
- Current Fuel Consumption
- Transmission Gear Oil Pressure
- Transmission Gear Oil Temperature
- Transmission Gear Position
- Active Service Codes
- Stored Service Codes from the Engine
- Set Units for Display (English or Metric)
- View Engine Configuration Parameters

Dimensions

Dimensions Flat Panel (only) Includes Shock Mounts

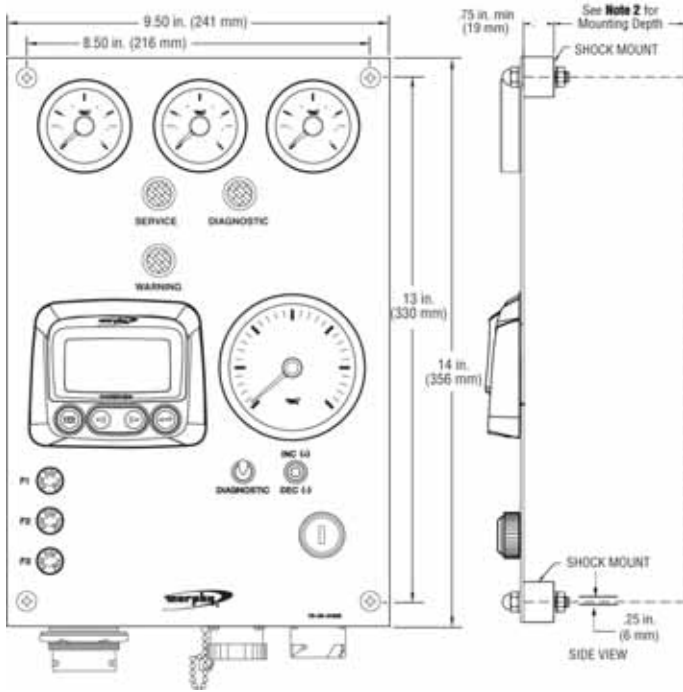

NOTE 1: Flat Panel has approximately 8 inch leads on connectors. Typical application shown, features vary per engine application.
NOTE 2: Allow 4.50 in. (114 mm) minimum mounting depth for versions with Morse throttle. For all other version allow 3.25 in. (83 mm) minimum depth.

Surface Mount Dimension (optional) Kit P/N 32-00-0033

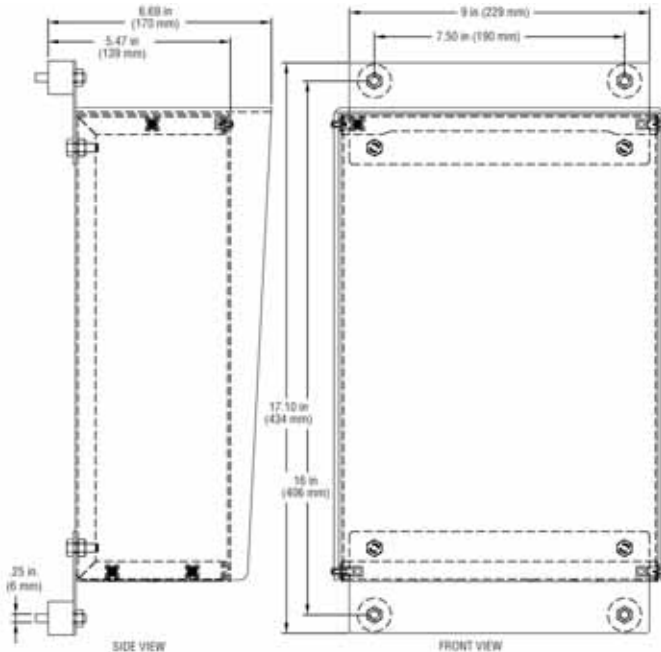

Dimensions in Enclosure Includes Shock Mounts

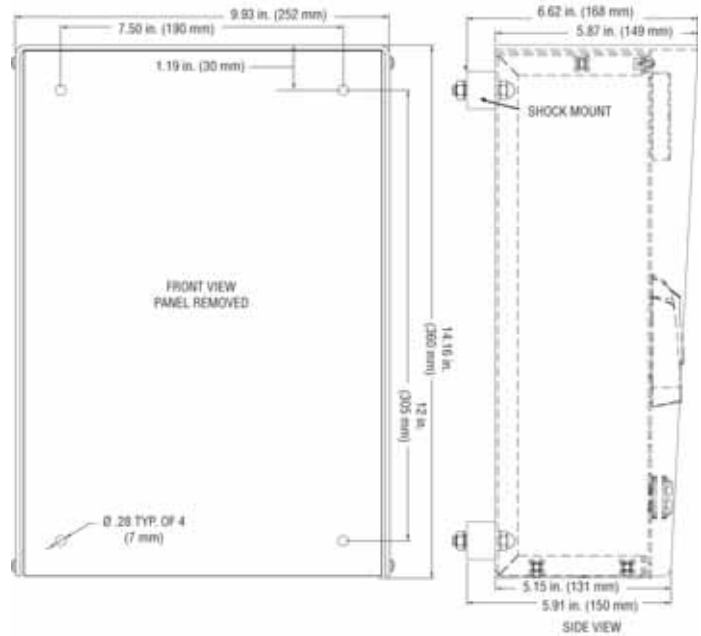

Recessed Mount Dimension (optional) Kit P/N 32-00-0035

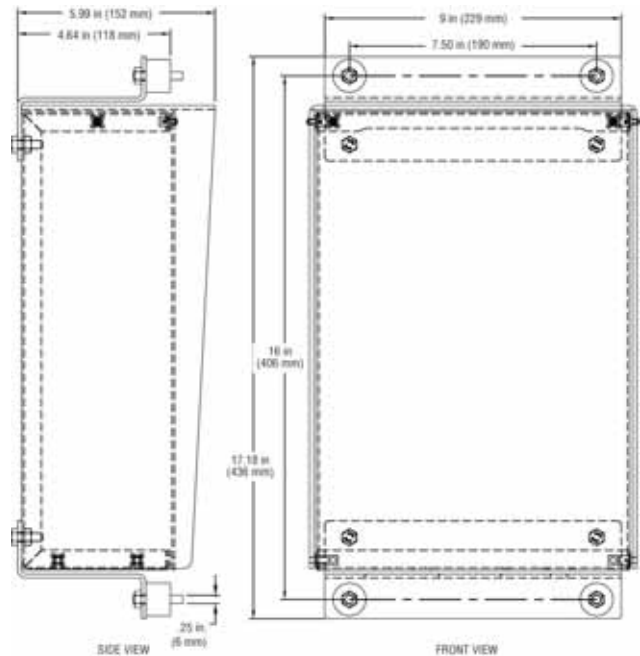

NOTE: It is the user's responsibility to verify that the electronic control module (ECM) has been programmed to support these control features, and that the appropriate external wire harness or other interconnecting wiring has been installed from the panel to the ECM.

Warranty - A limited warranty on materials and workmanship is given with this FW Murphy product. A copy of the warranty may be viewed or printed by going to <http://www.fwmurphy.com/warranty>

How to Order

To order, use the model number designation diagram below.

M-LINK M310 Panel Model Number Configurator for CUMMINS Engines

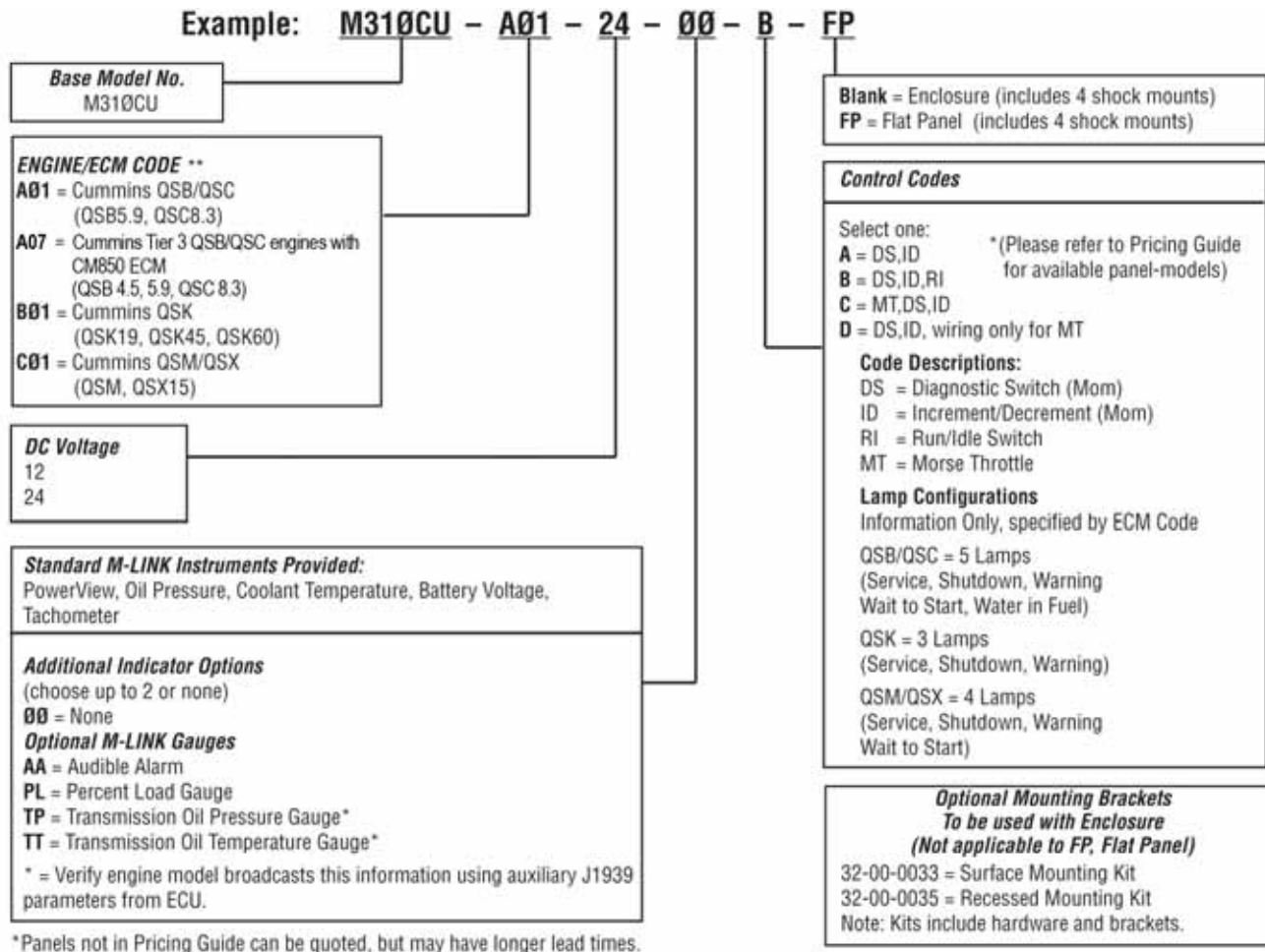

*Panels not in Pricing Guide can be quoted, but may have longer lead times.

**Contact FWMurphy sales if your engine is not listed

M-LINK External Harnesses for CUMMINS Engines

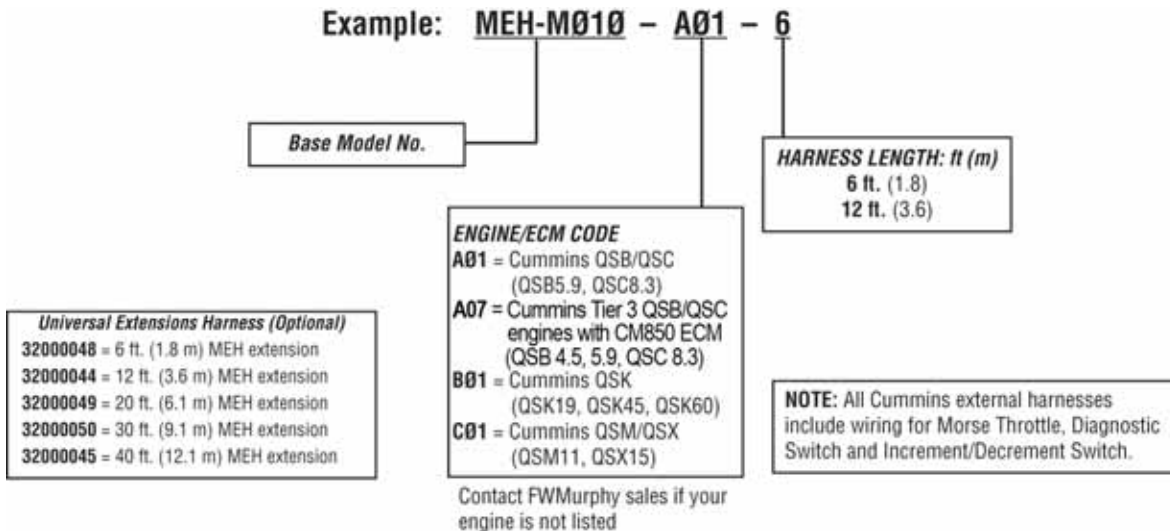

How to Order, continued

To order, use the model number designation diagram below.

M-LINK M310 Panel Model Number Configurator for CATERPILLAR Engines or Perkins 1100D

Example: **M310CA - A04 - 24 - 00 - C - FP**

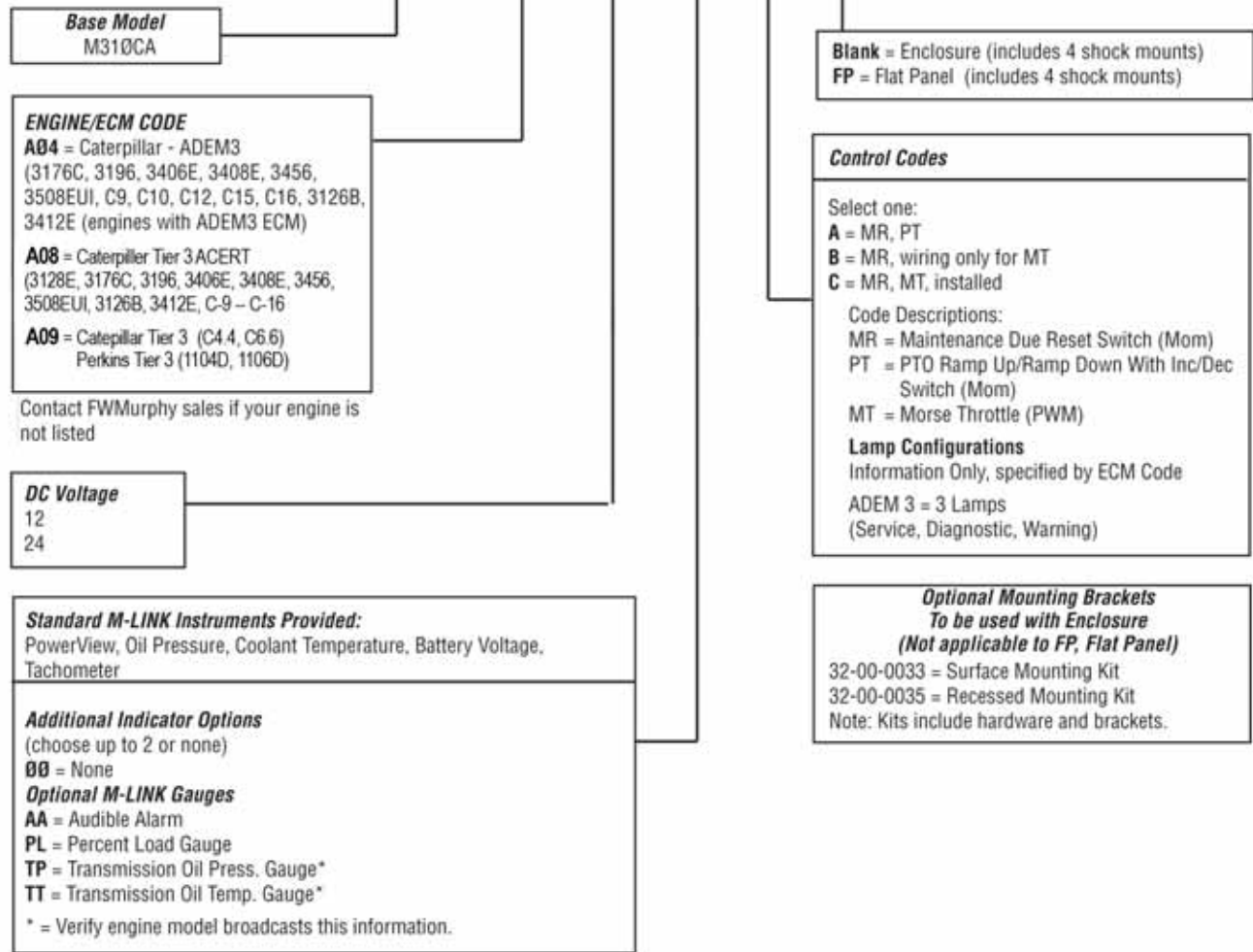

M-LINK External Harnesses for CATERPILLAR and Perkins 1100 Series Engines

Example: **MEH-M010 - A04 - 6**

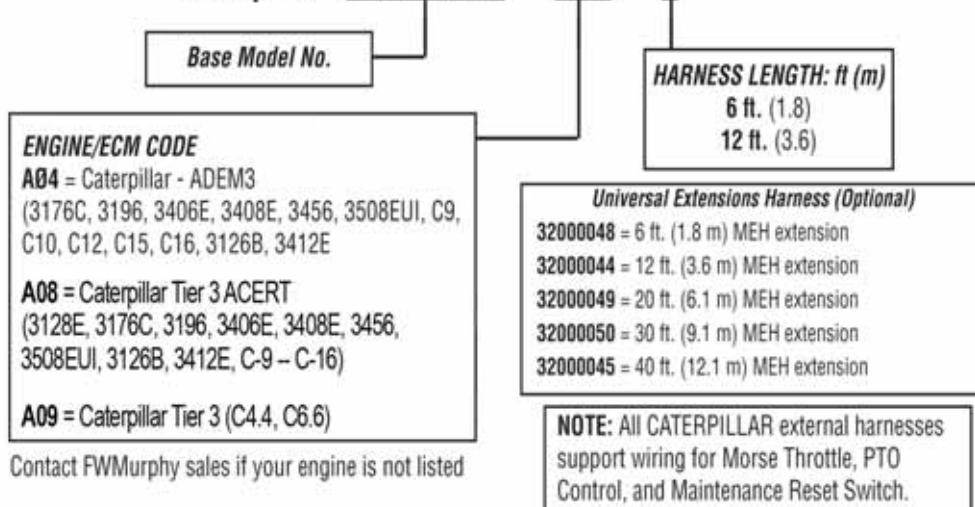

How to Order, continued

To order, use the model number designation diagram below.

M-LINK M310 Panel Model Number Configurator for PERKINS Engines–1100C Series or CATERPILLAR–3000E Series (ADEM4 ECM)

Example: **M310PK - B03 - 24 - 00 - C - FP**

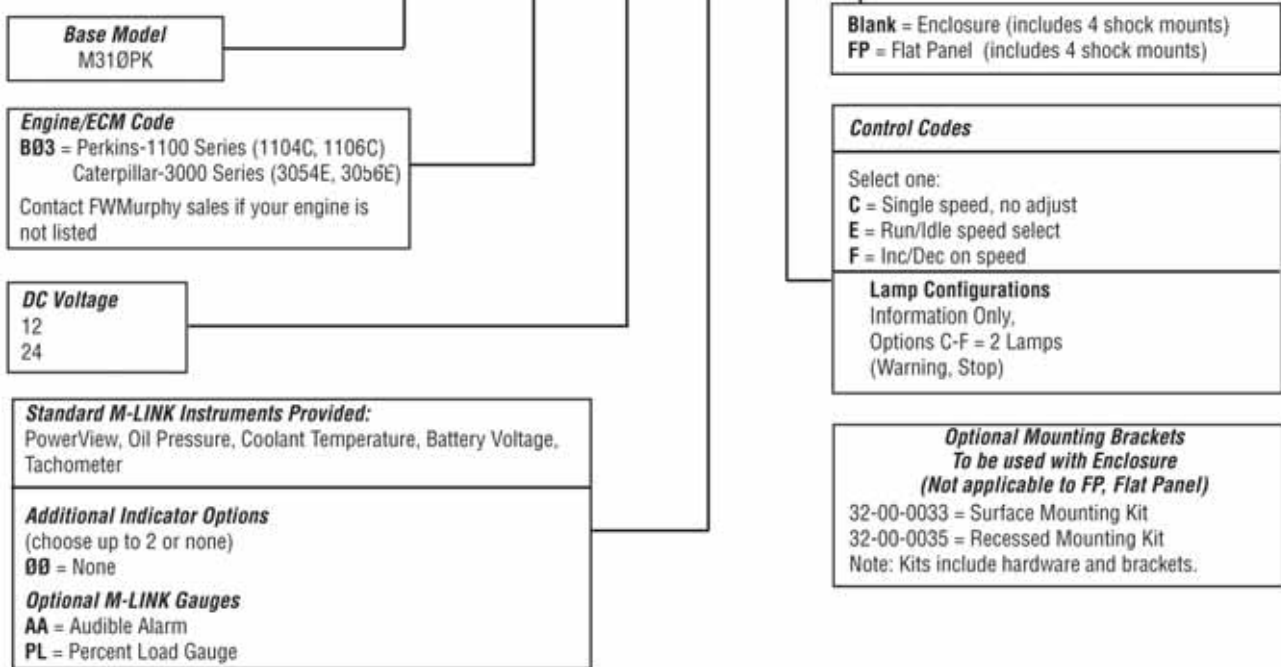

M-LINK External Harnesses for PERKINS–1100C Series or CATERPILLAR–3000E Series (ADEM4 ECM)

Example: **MEH-M010 - B03 - 6**

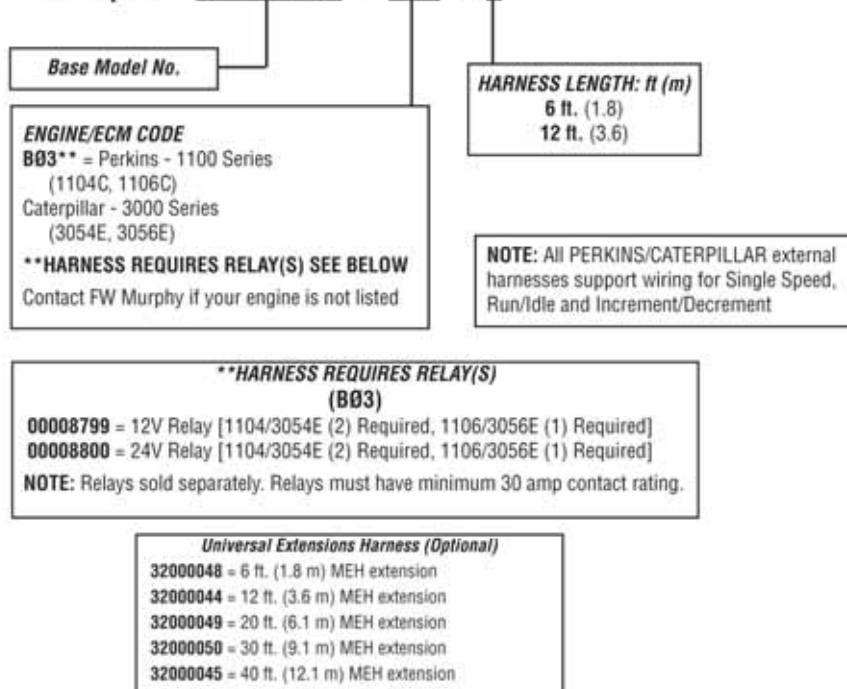

How to Order, continued

To order, use the model number designation diagram below.

M-LINK M310 Panel Model Number Configurator for PERKINS Engines–1300 Series and 2000 Series or DETROIT DIESEL–Series 40

Example: **M310PK - A03 - 24 - 00 - A - FP**

Base Model
M310PK

Engine/ECM Code
A03 = Perkins 1300 Series
 Detroit Series 40
 (IOPU/IOPU3/IOPU4)
B04 = Perkins Tier 3 (2000 Series)

Contact FWMurphy sales if your engine is not listed

DC Voltage
 12
 24

Standard M-LINK Instruments Provided:
 PowerView, Oil Pressure, Coolant Temperature, Battery Voltage, Tachometer

Additional Indicator Options
 (choose up to 2 or none)
00 = None

Optional M-LINK Gauges
AA = Audible Alarm
PL = Percent Load Gauge

Blank = Enclosure (includes 4 shock mounts)
FP = Flat Panel (includes 4 shock mounts)

Control Codes

Select one:
A = DS, IOPU2
B = DS, IOPU3/IOPU4

Code Descriptions:
 IOPU2= Standard Throttle (Resistive Potentiometer)
 IOPU3/IOPU4 = Variable/Preset Includes Variable/Preset Switch and Inc/Dec Switch (Mom)
 DS = Diagnostic Switch (Mom)

Included Sensors
 Barometric Air Pressure
 Ambient Air Temperature
 (APS trim pot included with either)

Lamp Configurations
 Information Only, specified by ECM Code
 1300 Series= 2 Lamps
 (Warning, Shutdown)

Optional Mounting Brackets
To be used with Enclosure
(Not applicable to FP, Flat Panel)
 32-00-0033 = Surface Mounting Kit
 32-00-0035 = Recessed Mounting Kit
Note: Kits include hardware and brackets.

M-LINK External Harnesses for PERKINS 1300 Series or DETROIT DIESEL–Series 40 Engines

Example: **MEH-M010 - A03 - 6**

Base Model No.

HARNESS LENGTH: ft (m)
 6 ft. (1.8)
 12 ft. (3.6)

ENGINE/ECM CODE
A03* = Perkins - 1300 Series
 Detroit Diesel Series 40
 (IOPU2/IOPU3/IOPU4)
B04 = Perkins Tier 3 (2000 Series)
***HARNESS REQUIRES RELAY SEE BELOW**

***HARNESS REQUIRES RELAY (A03)**
00008799 = 12V Relay
00008800 = 24V Relay
NOTE: Relay sold separately. Relay must have minimum 30 amp contact rating.

Universal Extensions Harness (Optional)
32000048 = 6 ft. (1.8 m) MEH extension
32000044 = 12 ft. (3.6 m) MEH extension
32000049 = 20 ft. (6.1 m) MEH extension
32000050 = 30 ft. (9.1 m) MEH extension
32000045 = 40 ft. (12.1 m) MEH extension

NOTE: All PERKINS 1300 Series/DETROIT DIESEL Series 40 external harnesses support wiring for both throttle control and Variable/Preset select with Increment/Decrement.

Contact FWMurphy sales if your engine is not listed

How to Order, continued

To order, use the model number designation diagram below.

M-LINK M310 Panel Model Number Configurator for DETROIT DIESEL Engines—Series 50/60 and Series 2000

Example: **M310DD - A02 - 24 - 00 - B - FP**

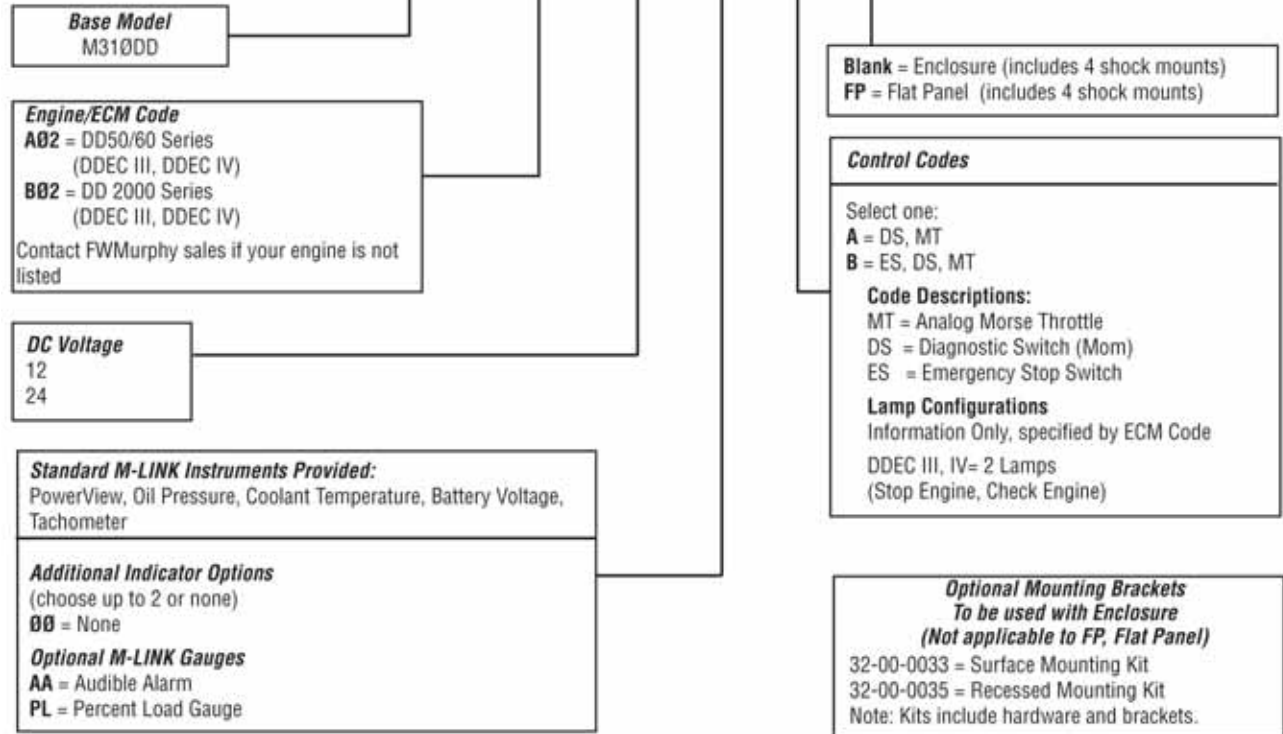

M-LINK External Harnesses for DETROIT DIESEL—Series 50/60 and Series 2000

Example: **MEH-M010 - A02 - 6**

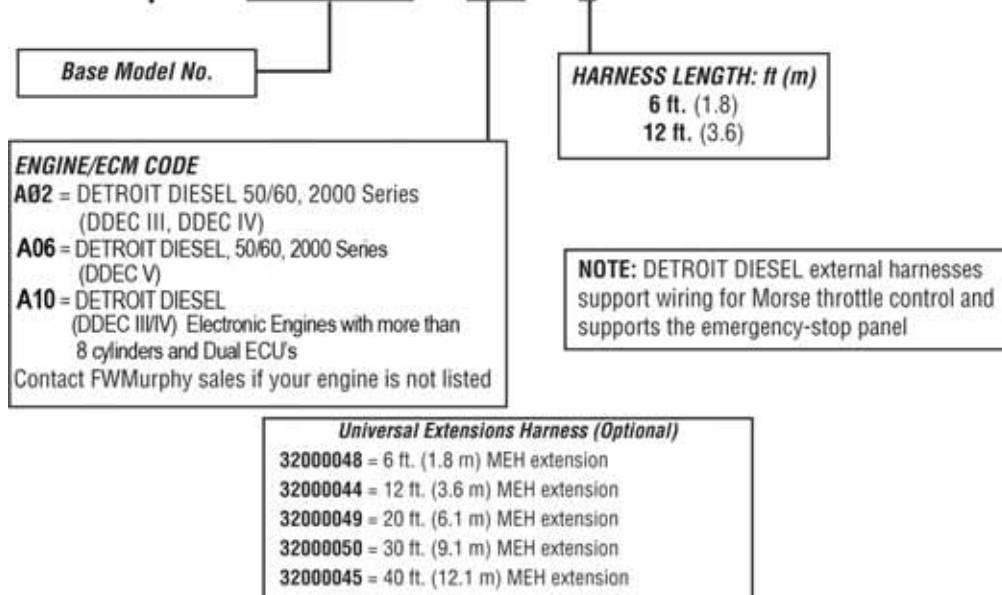

How to Order, continued

M-LINK M310 Panel Model Number Configurator for FORD Engines

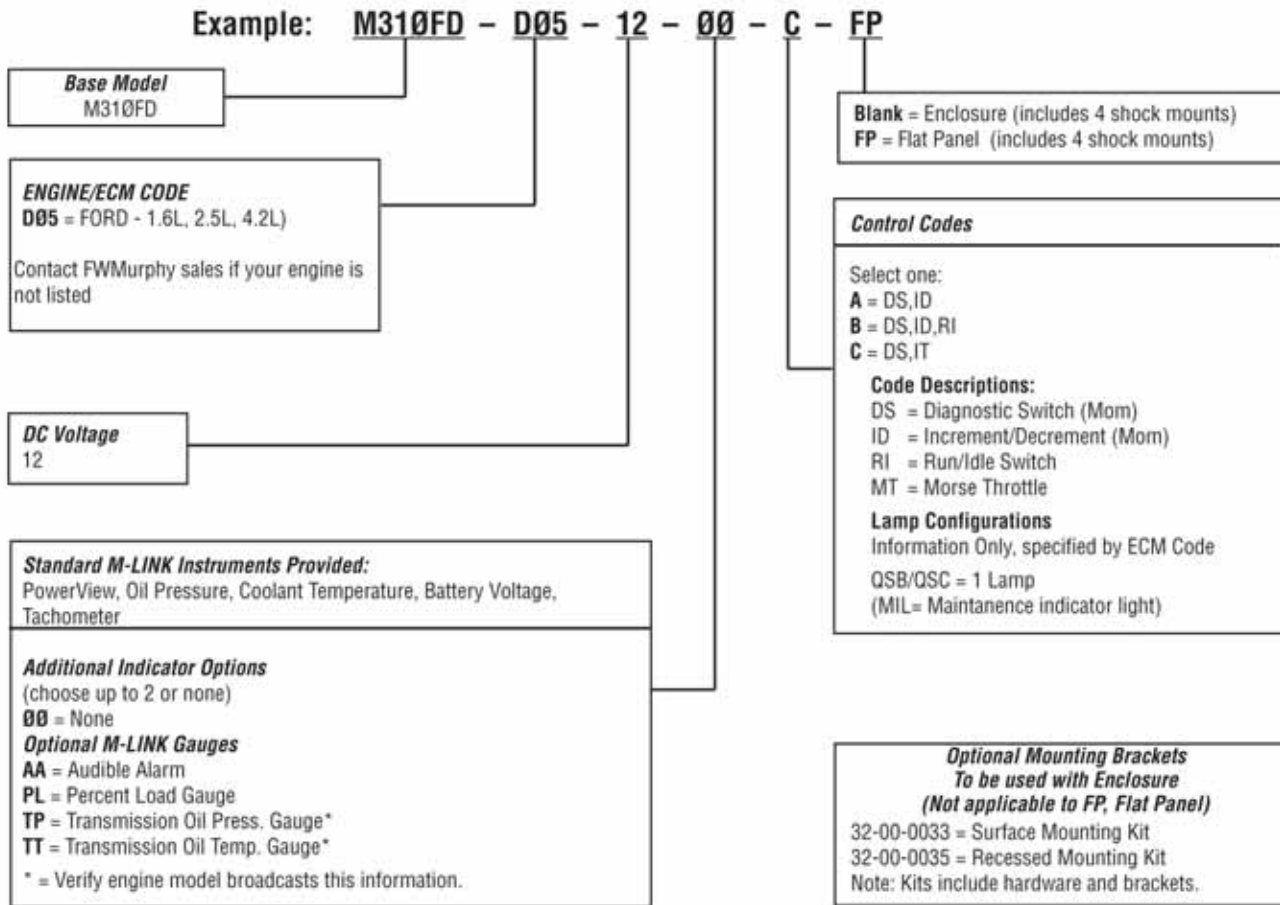

M-LINK External Harnesses for FORD Engines

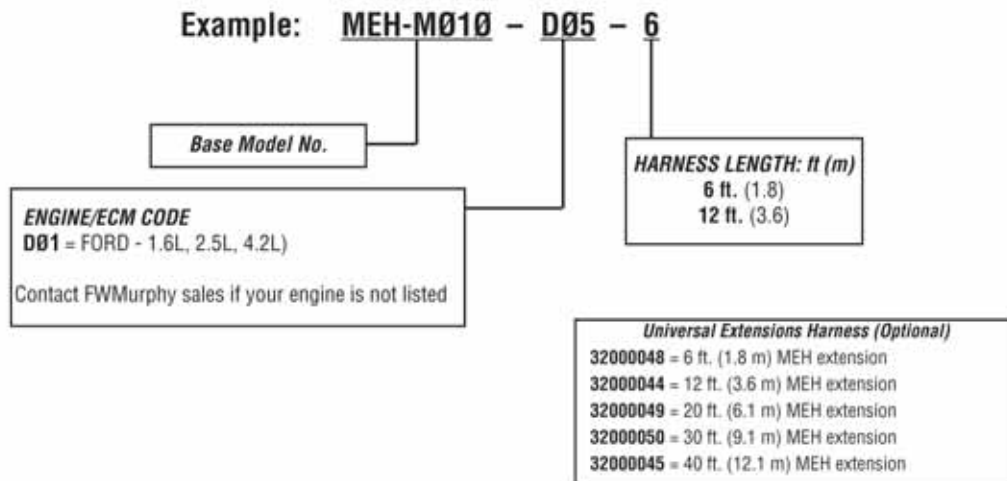

How or Order - continued

M-LINK M310 Panel Model Number Configurator for IVECO Engines

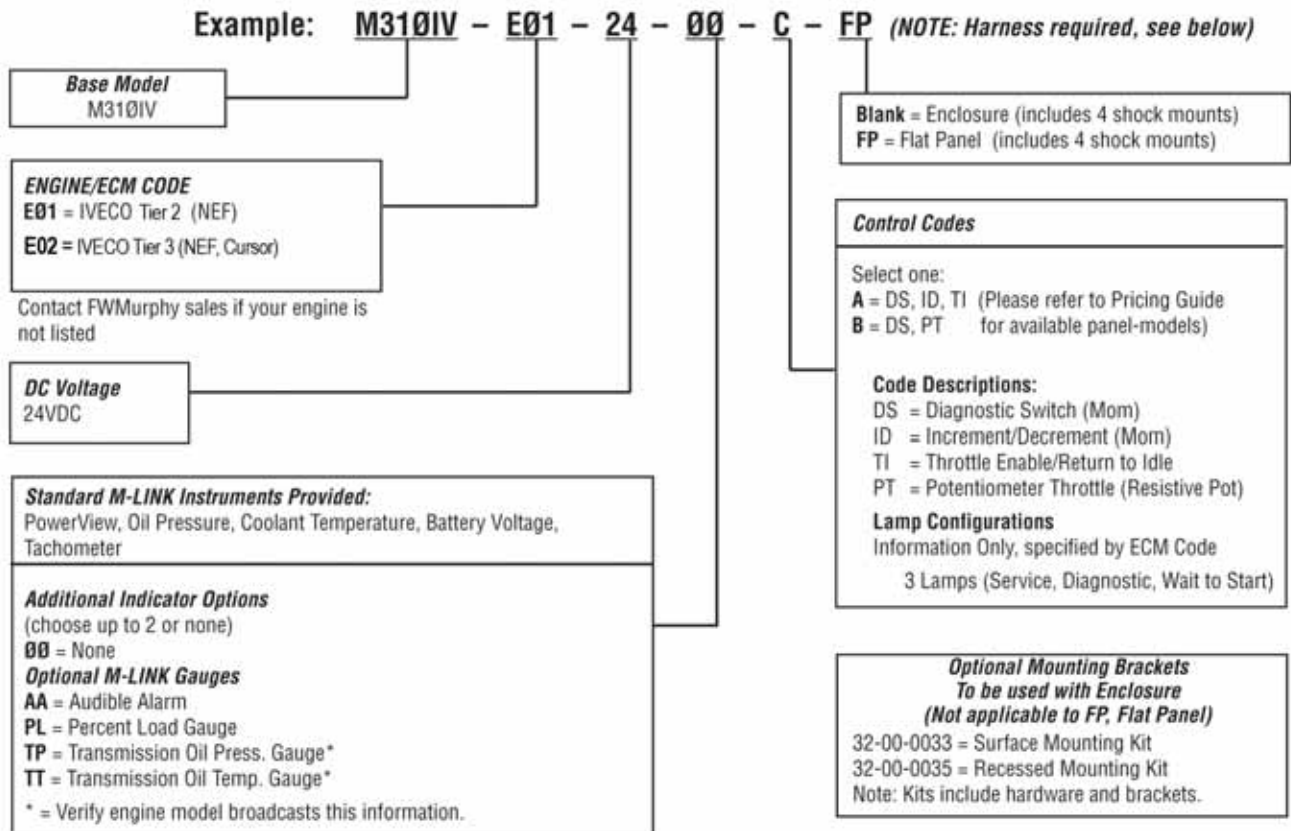

M-LINK External Harnesses for IVECO Engines

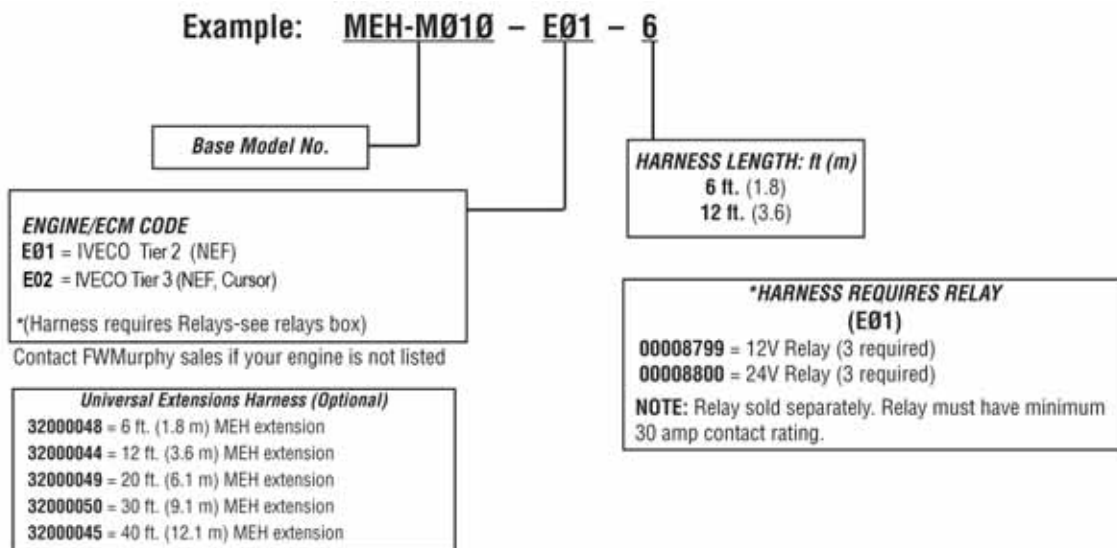

This page intentionally left blank.