

# Temperature Scanner/Pyrometer Switchgag<sup>®</sup> – Model TDX6



## Model TDX6



### Features

- Scans 6 Channels
- Rated for Class I, Division 2, Group D Hazardous Areas
- Start-up Time Delay
- Easy to Read Digital Display
- Accepts Type "J" or "K" Thermocouples Grounded<sup>‡</sup> or Ungrounded
- Field Adjustable Trip Points
- LCD Display in Either °F or °C (Specify)
- One Thermocouple Maybe Selected for Continuous Display
- CD Ignition, 24 VDC, or 120 VAC Powered
- No Special Training or Programming Required
- Scans All 6 Sensors in 30 Seconds



Approved<sup>†</sup>

\* When used with approved ignition. Contact Murphy for details.

† When used with power requirements described below.

‡ Using grounded thermocouples introduces the risk of odd currents or voltages being imposed on the thermocouple signal which can affect the accuracy of the reading. This is an inherent problem of grounded thermocouples, the reason why we prefer ungrounded thermocouples.

## Description

The TDX6 is an advanced design 6-point temperature scanner and pyrometer. It continually scans up to six thermocouples and sequentially displays the thermocouple number and its reading. Each sensor input has a field settable trip point for alarm, shutdown or control. A read/scan selector allows the operator to set and view each trip point. With the selector in the scan mode, a "thermocouple read" push button provides a means to manually toggle through the six channels and to lock in on a specific channel. Normal scanning will resume approximately three seconds after releasing the push button. All trip points are continually armed and active during the scanning process.

Type "J" or "K", grounded<sup>‡</sup> or ungrounded thermocouples are accommodated. Other types are available upon request.

The TDX6 can interface with other Murphy SELECTRONIC<sup>®</sup> TATTLETALE<sup>®</sup> annunciators and Micro-controllers. It is rated for Class I, Division 2, Group D, hazardous areas\* and is available for operation from CD ignition, 120 VAC, or 24 VDC.

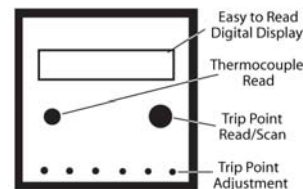

## Applications

- Gas Compressor Suction/Discharge Temp.
- Engine/Compressor Jacket Water Temperature
- Process Temperatures
- Generators
- Pumps
- Engine Exhaust Temperature

## Specifications

**Power Requirements (Operating Voltages):** 120 VAC or 80-250 VDC, CD ignition or 24 VDC.

### Outputs:

Models TDX6-A and TDX6-C: Six (6) isolated Silicon Controlled Rectifier (S.C.R.) outputs; 0.5 A @ 250 VDC; switches on (applies ground) above trip point and switches off (removes ground) when power is switched off.

Models TDX6-B and TDX6-D: Six (6) isolated Field-Effect Transistor (F.E.T.) outputs; 0.1 A @ 250 VDC; switches on (applies ground) above trip point and switches off (removes ground) below trip point.

**Operating Temperature:** -4 to 158°F (-20 to 70°C).

**Storage Temperature:** -40 to 300°F (-40 to 150°C).

**Case:** ABS 1/4 DIN (90 x 90 mm).

**Scanning Speed:** Complete scan in 30 seconds.

**Reset Differential:** F.E.T. models: Decreases 3 Degrees (°F or °C). S.C.R. models: Turn input power off to reset.

**Display Update Time:** Updates temperature every 0.3 seconds.

**Start-up Time Delay:** Unit is locked out for 10 seconds after ignition voltage is sensed.

**Ambient Cold Junction Compensation Range:** 2°F from 32°F to 122°F (1°C from 0°C to 50°C).

**Measurement Range:** Monitor Range 0-1999°F or °C (specify °F or °C in part number).

### Accuracy:

With J-type thermocouple: from 50-150°F (10-66°C) +3°F(+2°C), from 150-1200°F (66-649°C) ±1.0% of reading.

With K-type thermocouple: from 400-2000°F (204-1076°C) ±1.0% of reading.

**Trip Point Accuracy:** ±3°F (±2°C) of reading.

**Trip Point Adjustment Range:** 0-1999 Degrees.

**Open Thermocouple Input:** A number 1 appears in the display to the right of the channel number and the trip point operates.

**Shipping Weight:** 2 lb. (0.91 kg).

**Shipping Dimensions:** 5-1/2 x 9 x 6 in. (140 x 229 x 152 mm).

## Dimensions

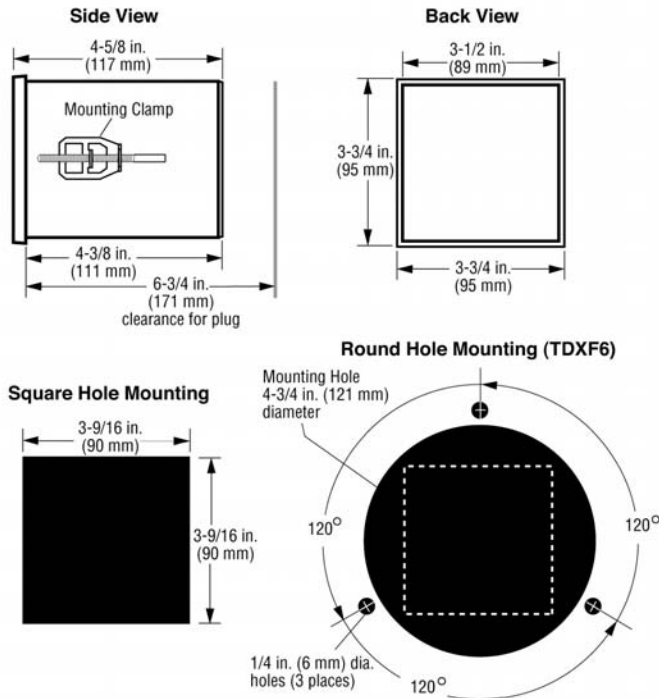

## Typical Wiring Diagram

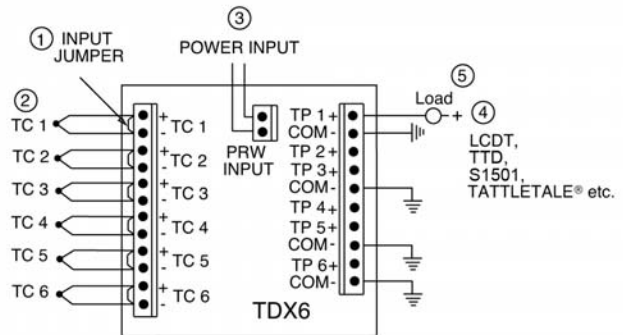

### NOTES:

- ① Remove input jumper when the thermocouple is connected to input.
- ② Thermocouple Input
- ③ Power input 120 VAC, 80-250 VDC, CD ignition or 24 VDC, positive or negative ground.
- ④ Interfaced components must meet area classification requirements.
- ⑤ When using the TDX6 with inductive loads, we recommend installing a suppression diode across all coils.

## TDX6 Interface Capabilities

Model	Power Source	Rating
LCDT	CD Ign., 120 VAC, 12/24 VDC	Cl.I, Div.1, Gr.D, Haz. areas*
S1501	120 VAC or 12/24 VDC	Cl.I, Div.1, Gr.D, Haz. areas*
TTD	CD Ignition ( neg. grnd), 12/24 VDC	Cl.I, Div.2, Gr.D, Haz. areas†
TATTLETALE®	CD Ign., 120 VAC, 12/24 VDC	Non-Hazardous areas

\* Note: An isolation barrier is needed between the TDX6 and an Annunciator rated for Class I, Division 1, Group D, Hazardous Areas.

† Note: When used with approved ignition. Contact Murphy for details.

**PLC's, various non-Murphy annunciators—contact factory.**

## How to Order

To order the TDX6 use the part number designation diagram below.

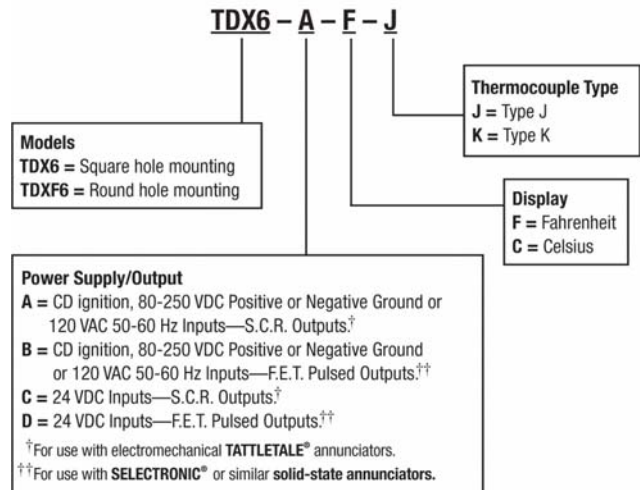

美国Murphy仪表经销商：

北京

信德迈科技(北京)有限公司 CNMEC Technology

北京朝阳区胜古中路2号金基业大厦201室

邮编：100029

电话：010-8428 2935 13910962635

传真：010-8428 8762

主页：//www.cnmec.com

电子邮件：sales@cnmec.biz

**Warranty** - A limited warranty on materials and workmanship is given with this FW Murphy product.  
A copy of the warranty may be viewed or printed by going to <http://www.fwmurphy.com/warranty>