

Dual Temperature SWITCHGAGE® Model Series MDTM89



Features

- Monitor inputs from two thermocouples
- Adjustable switch trip point for each input
- FET or SCR output
- Power from CD ignition or 120 VAC or 12/24 VDC
- Types "J" or "K" ungrounded thermocouples
- Digital readings in Fahrenheit or Celsius



Approved*



Approved†

* When used with approved ignition or 12-24 VDC. Contact Murphy for details.

† Approved for CD ignition, 80–250 VDC.

Murphy's model MDTM89 is an electronic, dual-temperature monitor. It monitors two thermocouples, displays the temperature of the thermocouple selected, and has adjustable trip points for each input. A toggle switch provides for selection of the thermocouple to be displayed and/or the temperature trip point to be checked/adjusted. If either trip point is reached, the associated output "turns on" and can be used as a control signal, or to initiate alarms and/or shutdown.

A "Push to Read" button, located below the selector switch, allows the operator to check the trip point and to see its value as adjustments are made. Two potentiometers, one on each side of the thermocouple selector switch, are provided for field-adjustment of the trip points.

There are four basic models. Two of the models are powered by capacitor discharge ignition, and have either an FET or an SCR output. One model operates from 12 or 24 VDC and has an FET output. One model operates from 120 VAC by use of an isolation module and has an FET output. Standard display is in degrees Fahrenheit; degrees Celsius is optional.

Applications

Applications include the following:

- Compressor suction/discharge temperature
- Engine/compressor jacket water temperature
- Engine exhaust temperature
- Compressor cylinder temperature
- After cooler temperature
- Bearing temperature

Thermocouple Type

Either "J" or "K" type **UNGROUND**ED THERMOCOUPLE is accepted. Specify type in part number for each MDTM89 unit (see How to Order information on back page).

Order thermocouples as a separate item.

Automatic Cold Junction Reference

Cold junction reference point compensation is an integral feature of the monitor. The compensator circuit monitors case temperature and automatically compensates for changes in ambient temperatures. Compensation will allow maximum of 2 degrees change in the temperature reading from 32 to 122°F (0 to 50°C).

Open Thermocouple Input

An open thermocouple input forces the monitor into upscale overrange. The monitor indicates an overrange by displaying the numeral 1 (one) in the left most digit of the display. An overrange will turn on the high trip point output.

Trip Point Operation

Monitored trip points are independent of the thermocouple selector switch. Both set points are always active.

When the thermocouple temperature reaches the trip point temperature, the MDTM89 is triggered. After approximately 0.5 seconds the trip point output "turns on".

Trip points are set by depressing the "Push to Read" push button while rotating a trip point potentiometer until the desired trip point temperature is displayed.

Continuous & Trip Point Display

The selector switch is used to select the thermocouple or trip point temperature to be displayed. The selected temperature is continuously displayed during normal operation. Depressing the "Push to Read" push button displays the trip point temperature of the selected thermocouple.

In order to consistently bring you the highest quality, full featured products, we reserve the right to change our specifications and designs at any time. MURPHY products and the Murphy logo are registered and/or common law trademarks of Murphy Industries, LLC. This document, including textual matter and illustrations, is copyright protected by Murphy Industries, LLC, with all rights reserved. (c) 2010 Murphy Industries, LLC.

Specifications

Power Requirements (Operating Voltages):

MDTM89-A: 100 to 350[†] VDC, CD ignition, negative ground (FET outputs).

MDTM89-E: 100 to 350^{*}, CD ignition, negative ground (FET outputs).

MDTM89-B: 100 to 350^{*} VDC, CD ignition, negative or positive ground (SCR outputs).

MDTM89-C: 12 to 24[†] VDC, negative ground, 15 milliwatts (FET outputs).

MDTM89-D: 120 VAC (MDTM89-C with 120 V isolation module #IT-1) (FET outputs.) Model NOT approved by CSA or Factory Mutual.

Power Consumption: CD ignition: 350 μ A @ 100V; 120 VAC: 0.6 watts; 24 VDC: 0.5 watts.

Outputs: Model B: output turns on above trip point; output turns off when power is switched off; two (2) isolated SCR outputs, 0.5 amp @ 250 VDC.

Models A, C and D: output turns on above trip point; output turns off below trip point; two (2) isolated FET outputs, 0.5 amp @ 250 VDC.

Model E: output one turns on above trip point, output turns off below trip point; output 2 turns on below trip point, output turns off above trip point; two (2) isolated FET outputs, 0.5 amp @ 250 VDC.

* Approved for CD ignition, 80–250 VDC.

† When used with approved ignitions or 12-24 VDC. Contact Murphy for details.

Ambient Cold Junction Compensation Range: 32 to 122°F (1°C from 0 to 50°C).

Operating Temperature: -4 to 158°F (-20 to 70°C).

Storage Temperature: -40 to 300°F (-40 to 150°C).

Case: Die cast aluminum.

Reset Differential: FET models: Decreases 3 Degrees (°F or °C).

SCR model: turn input power off to reset.

Measurement Range: Monitor Range 0-1999°F or °C (specify "F" or "C" in part number).

Accuracy: With J-type thermocouple: from 150-1200°F (66-649°C) \pm 1.5% of reading. With K-type thermocouple: from 400-2000°F (204-1076°C) \pm 1.5% of reading. At calibration temperature.

Laboratory Approvals: CSA† and Factory Mutual* approved for Class I, Division 2, Group D, hazardous locations).

Thermocouple Lead Length: 150 ohm lead resistance affects monitor accuracy less than 1°.

Trip Point Accuracy: \pm 3°F (\pm 2°C) of reading.

Trip Point Adjustment Range: 0-1999 Degrees.

Shipping Weight: 48 ozs (1.4 kg).

Shipping Dimensions: 10 x 9-1/2 x 6 in. (254 x 241 x 152 mm)

Dimensions

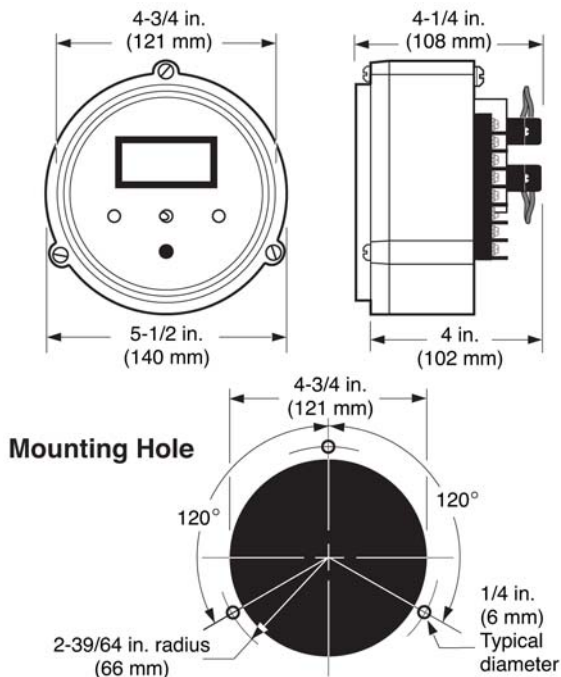

How to Order

MDTM89- F - A - K

Calibration
F: Fahrenheit
C: Celsius

Type of **ungrounded** thermocouple to be used; "J" or "K".

Powered by and type output:

A: CD ignition, 100–350 VDC, output by FET (Field Effect Transistor, 0.5 A @ 250 VDC maximum).

E: CD ignition, 100–350 VDC, output by FET (Field Effect Transistor, 0.5 A @ 250 VDC maximum).

B: CD ignition, 100–350 VDC, output by SCR (Silicon Controller Rectifier, 0.5 A @ 250 VDC maximum).

C: 12 to 24 VDC, 15 mw, output by FET

D: 120 VAC, output by FET (same as "C" with a 120 VAC–24 VDC power supply [#IT-1])

MDTM89 Interface Capabilities

Model	Power Source	Rating
LCDT	CD Ign., 120 VAC, 12/24 VDC	Cl.I, Div.1, Gr.D, Haz. areas*
S1501	120 VAC or 12/24 VDC	Cl.I, Div.1, Gr.D, Haz. areas*
TTD	CD Ign., 12/24 VDC	Cl.I, Div.2, Gr.D, Haz. areas**
TATTLETALE®	CD Ign., 120 VAC, 12/24 VDC	Non-Hazardous areas

PLC s, various non-Murphy annunciators—contact factory.

*An isolation barrier is needed between the MDTM89 and an Annunciator rated for Class I, Division 1, Group D, Hazardous Areas.

**When used with approved ignition. Contact Murphy for details.



北京

信德迈科技(北京)有限公司 CNMEC Technology

北京朝阳区胜古中路2号金基业大厦201室

邮编: 100029

电话: 010-8428 2935 13910962635

传真: 010-8428 8762

主页: //www.cnmec.com

电子邮件: sales@cnmec.biz

Warranty - A limited warranty on materials and workmanship is given with this FW Murphy product. A copy of the warranty may be viewed or printed by going to <http://www.fwmurphy.com/warranty>