

Level Maintainer – LM300 Series



LM301-EX

Patent 5493086



Features

- Maintains proper lube level
- Shutdown on low level, or high and low level
- Low level alarm before shutdown
- Manual float switch test
- High visibility “Frog Eye” lens
- Optional pipe or universal mounting brackets
- Optional inlet orifices for low to high pressure applications
- Explosion-proof models available

*

†

* Pending

† Products covered by this bulletin comply with Directive: 2004/108/EC (European Electromagnetic Compatibility). European Harmonised standard: EN 61000-6-3:2007 (Emissions). EN 61000-6-1:2005 (Immunity).

The LM300 Series Level Maintainer automatically adds oil to the crankcase as needed to keep the lube level normal. Most models have built-in switches that will alarm and/or shutdown the equipment if the makeup supply is depleted and engine oil level falls or if overfill conditions exist. LM300 series explosion-proof models are CSA certified† for Class I, Division 1 Hazardous areas.

Applications

- Engines
- Compressors
- Pumps
- Coolers

Base Models‡

LM300: Level Maintainer only (no switches).

LM301: Low switch contacts for low level shutdown or alarm. Four wires, SPDT.

LM302: Two switches for low and high level shutdown or alarm. Four wires, DPST, wired N.O. in normal operating ranges.

LM303: Two switches for low and high level shutdown or alarm. Four wires, DPST, wired N.C. in normal operating ranges.

Specifications

Case/Cover: Die cast aluminum.

Switch Housing: Aluminum.

Approval Rating: LM301 thru LM305: CSA certified† for non hazardous locations. Enclosure Type 4 certified.
LM301-EX thru LM305-EX: CSA certified† for Class I, Groups C and D; Class II, Groups F and G hazardous locations. Enclosure Type 4 certified.

Float: Rigid polyurethane foam. Polyurethane coated.

Max. Ambient Temperature: 250°F (121°C)

Oil Inlet Connection: Top entry 1/2-14 NPT with built-in filter screen (removable for cleaning).

Inlet Orifices: 1/4 in. (6 mm) standard. 1/8 in. (3 mm) available.

Wire (switch models): 18 AWG x 13 in. (1.0 mm² x 330 mm).

Max. Inlet Pressure (MIP): 30 psi (207 kPa) [2.07 bar], with 1/8 in. (3 mm) orifice.
15 ft oil (4.6 m oil) with 1/4 in. (6 mm) orifice.

Max. Differential: 2 in. (51 mm) between running and stationary oil level.

Max. Case Pressure (MCP): 15 psi (103 kPa) [1.03 bar].

Orifice Seal[†]: Buna-N Thumb-Valve™

Switch Contact: Silver, SPDT snap acting, rated at 10 A @ 125, 250 VAC; 10 A @ 30 VDC. (1 only for low level; 2 only for high and low; or 2 only for low level with alarm before shutdown)

Flow Rate Test: Using SAE 30 @ 32°F (0°C).

Orifice Diameter	Pressure	Flow Rates
1/4 in.* (6 mm)	4 ft. oil – 15 ft. oil (1.2 m oil – 4.6 m oil)	4.7 GPH - 31.0 GPH (17.8 LPH - 117.3 LPH)
1/8 in. (3 mm)	10 psig – 30 psig (68.9 kPa – 207 kPa) [.69 – 2.07 bar]	16.9 GPH - 32.1 GPH (63.7 LPH - 121.5 LPH)

* Standard

■ NOTE: Friction losses due to piping NOT considered.

Outlet Connection: 3/4-14 NPT left side, right side, and bottom.

Crankcase Balance Vent Fitting: 1/2-14 NPT.

Mounting: Accepts Murphy pipe mounting bracket or universal mounting bracket.

Lens: Clear “Frog Eye” non-staining, high impact, high temperature nylon; UV and heat stabilized.

Dial: High visibility white background with green and white “index” lines for normal level indication.

Test Knob: Rotate to test switch operation. Turn clockwise for low level test and turn counterclockwise for high level test.

† CSA certified with switch contacts rated at 10 A at 250 V AC (standard).

‡ Specify “EX” for explosion-proof enclosure. All models **except LM300** are available in an explosion-proof enclosure.

Dimensions

The dimensions below are for the optional "EX" model enclosure. The standard model enclosure dimensions are the same except the height and width which are: 7 in. (178 mm) H, 7-7/8 in. (200 mm) W.

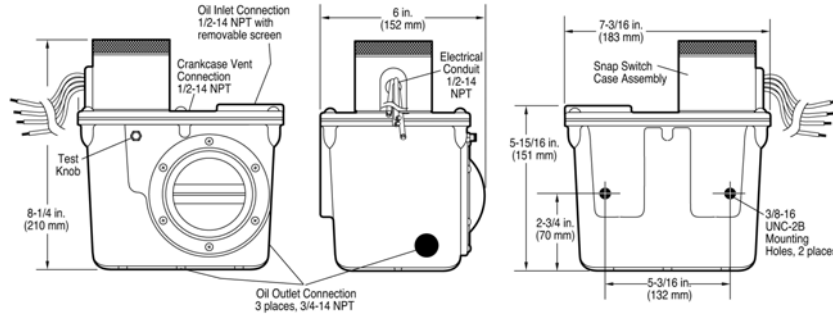

Mounting Brackets with Hardware

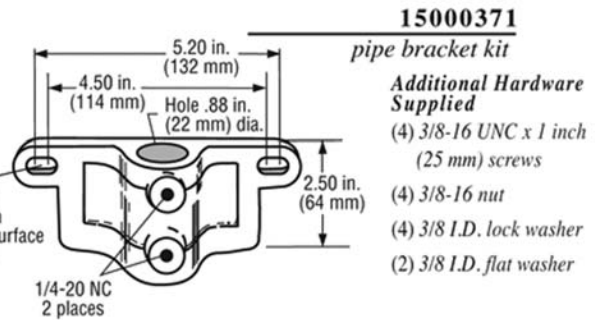
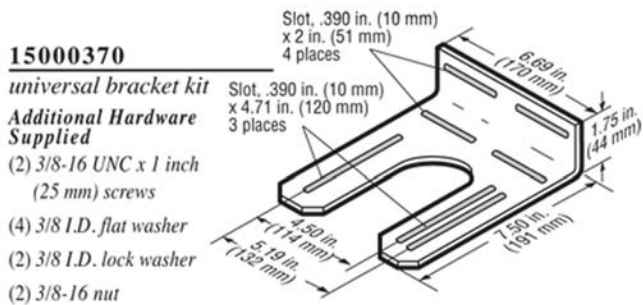

How to Order

Build a complete model number using the following chart. See example. See reverse page for standard and optional specifications.

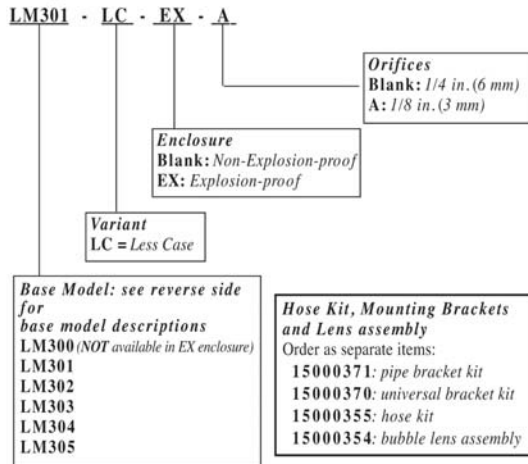

Shipping Information

Shipping Weights:

- LM300 Series non-"EX" models: 6 lbs. 6 ozs. (2.89 kg)
- LM300 Series "EX" models: 6 lbs. 12 ozs. (3.06 kg)

Shipping Dimensions (all LM300 Series models):

- 10-5/8 x 8-7/8 x 6-3/4 in. (270 x 225 x 171 mm)

Optional Hose Kit: 15000355

Quantity	Description
1	1/2 in. (13 mm) I.D. x 3 ft. (914 mm) long hose
1	1 in. (25 mm) I.D. x 3 ft. (914 mm) long hose
2	1/2 in. (13 mm) worm gear clamp
2	1 in. (25 mm) worm gear clamp
2	1/2 NPT x 1/2 in. (13 mm) barbed fitting
2	3/4 NPT x 1 in. (25 mm) barbed fitting

美国Murphy仪表经销商：

北京

信德迈科技(北京)有限公司 CNMEC Technology
 地址：北京朝阳区胜古中路2号金基业大厦201室
 邮编：100029
 电话：010-8428 2935 13910962635
 传真：010-8428 8762
 主页：//www.cnmec.com
 电子邮件：sales@cnmec.biz