

Swichgage® Shutdown Panel Kit



W0168 and W0241

- Protection Against Dangerously Low Oil Pressure or High Temperature
- Closed-loop Circuitry Ensures Proper Operation at All Times
- Operates on 12 or 24 VDC Systems*
- Complete Kit Ready for Easy Installation
- Universal Mounting Panel

Description

The W0168 and W0241 panel kits are universal-fit instrument panels for most industrial engines. They include Swichgage protection for low engine oil pressure and high coolant or high oil temperature. These Panel Kits are similar—the W0168 has a start/stop key switch and the W0241 has a start push button.

Panel kits include:

- Low Lube Oil Pressure Swichgage instrument.
- High Coolant/Oil Temperature Swichgage.
- 518PH Magnetic Switch.
- Emergency stop push button.
- Ignition key switch for start/stop (W0168).
- Push button for start (W0241).
- Ammeter 60-0-60.
- Provisions for additional Swichgage controls, such as irrigation pump pressure or engine oil temperature.
- Provisions for tachometer and throttle cable.

Swichgage product is two-instruments-in-one: (1) an accurate indicating gage with (2) a built-in, adjustable limit switch.

A **518PH Magnetic Switch** provides a Closed-loop circuit to ensure proper operation at all times. The 518PH allows the system to be sensitive to open circuits, broken wires, false grounds, corrosion, loss of power and other factors which could otherwise prevent the protective controls from operating. It can be wired to either make or break a circuit for shutdown.

The universal mounting panel is enclosed on all 4 sides with open back. An optional back cover (model no. 30050800) is available for both kits. Panel Kits are prewired and ready to install and are available for 12 or 24 VDC systems.*

Specifications

Low Lube Oil Pressure Swichgage

Instrument:

- 0-100 psi (0-689 kPa) [0-6.89 bar]
- 1/8 NPT process connection

High Coolant/Oil Temperature Swichgage Instrument:

- 130-250°F (54-121°C)
- 48 in. (1.2 m) capillary
- 1/2 NPT process connection

518PH Magnetic Switch:

12 or 24 volt (specify)

Ammeter: 60-0-60

Shipping Weight: 8 lbs. 8 ozs. (3.9 kgs.)

Shipping Dimensions:

16 x 11 x 5-1/2 in. (406 x 279 x 140 mm)

Warranty

A limited warranty on materials and workmanship is given with this FW Murphy product. A copy of the warranty may be viewed or printed by going to www.fwmurphy.com/support/warranty.htm

How to Order

To order a Shutdown Panel Kit for your application, specify model number.

W0168

W0168B (back cover)

W0241

*NOTE: 12 volt kit is standard. If you require 24 volt kit—specify when ordering.



Dimensions

Dimensions below are for both Panel Kits.

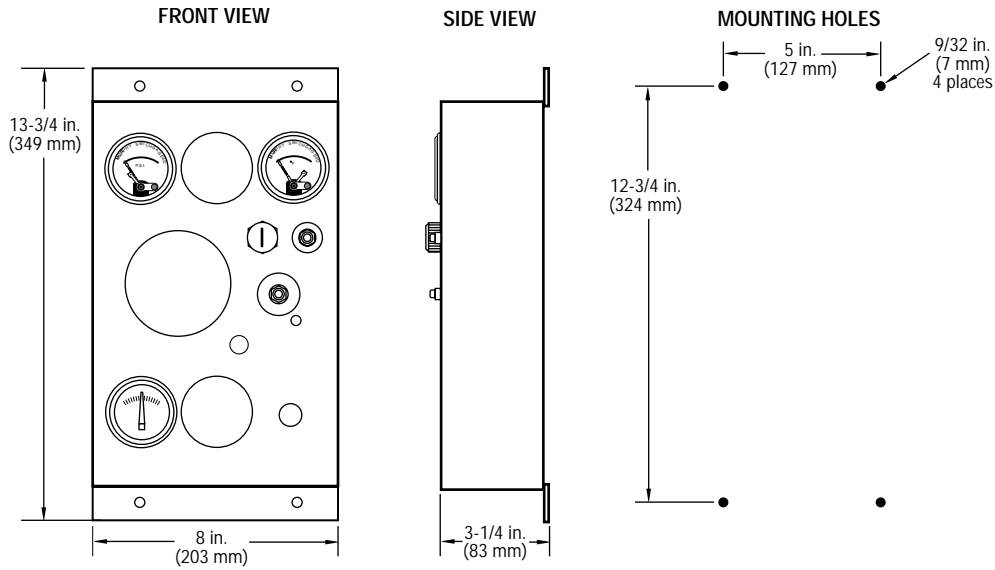

Typical Wiring Diagram

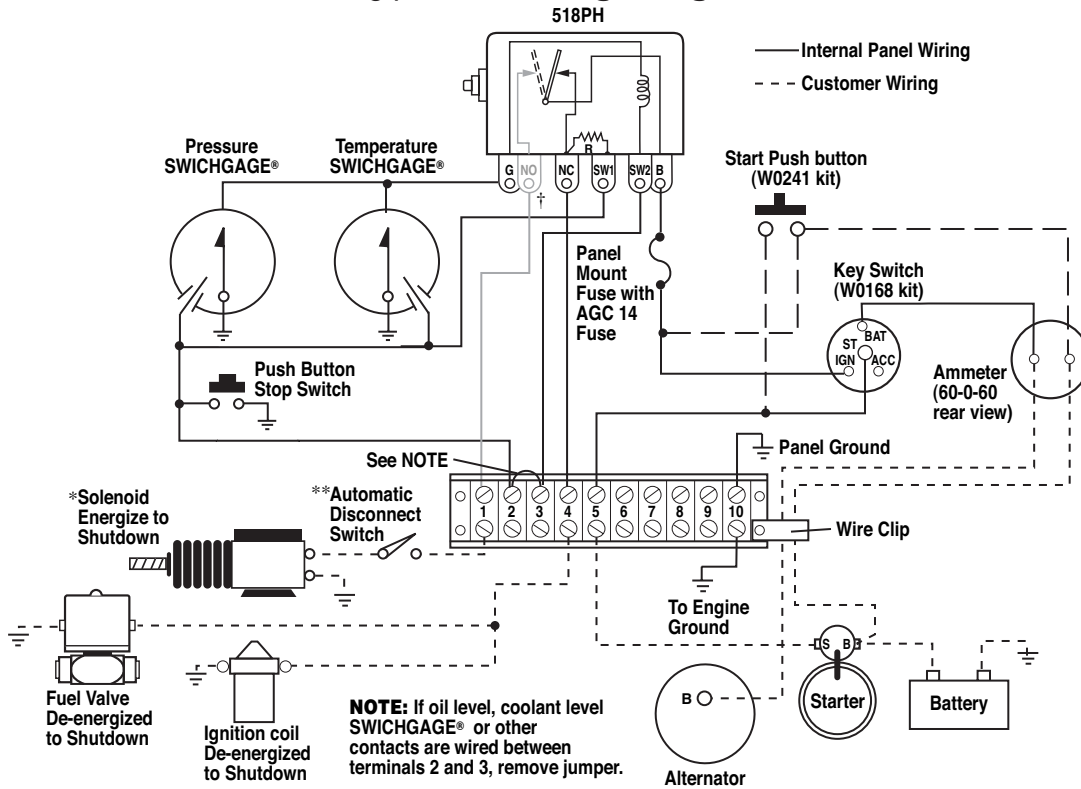

*Key Switch must remain in "ON" position.
 **Such as N.O. fuel pressure switch part number 00-00-0421.



北京

信德迈科技(北京)有限公司 CNMEC Technology
 地址：北京市朝阳区安贞桥胜古中路2号金基业大厦201室
 邮编：100029
 *Tel: 010-8428 2935 | * Fax: 010-8428 8762
 *手机：139 1096 2635
 *电子邮件：sales@cnmec.biz
 主页：http://www.cnmec.com