

Swichgag[®] Diagnostic Panel Kits For Cummins B and C-Series Engines

CMNS-97077B
Revised 05-08
Catalog Section 30
(00-02-0085)



W0162 and W0163

- Includes Swichgag Instruments for Critical Engine Protection
- Complete and Ready to Install
- Provision for Throttle Cable
- Fits B and C-Series Open or Closed Power Units

Description

Designed specifically for Cummins B and C-Series engines, these kits are complete with all components ready for installation.

These kits include our exclusive SWICHGAGE[®]s for basic engine protection.

A Closed-loop protective circuit is provided by Murphy 518PH magnetic switch to ensure proper operation at all times.

Features

- Unitized kit with all components
- Shock mounted panel fully assembled
- Closed-loop circuit
- Provision for additional Swichgag instruments, such as irrigation pump pressure
- Provision for tachometer and throttle cable
- Complete wiring harness allows easy installation

Dimensions (Dimensions below are for both kits)

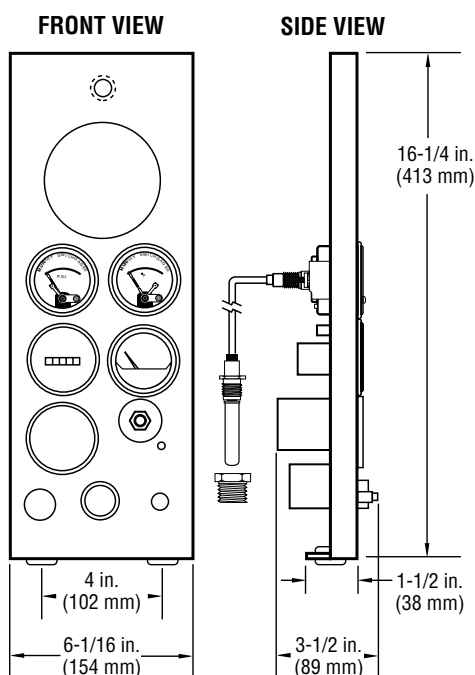

Kit Includes

- Oil pressure Swichgag instruments
- Coolant temperature Swichgag instruments
- Voltmeter
- Hourmeter
- Emergency stop push button
- Key or push button start (specify)
- Face mounted fuse
- Starter auxiliary solenoid kit (complete)
- Necessary bolts, nuts, etc. for complete kit mounting

How to Order: Order by model number.

W0162: Includes an ignition key start

W0163: Includes push button start.

(Optional) DHK: Deluxe oil pressure line assembly

Warranty

A limited warranty on materials and workmanship is given with this FW Murphy product. A copy of the warranty may be viewed or printed by going to www.fwmurphy.com/support/warranty.htm





WARNING

BEFORE BEGINNING INSTALLATION OF THIS MURPHY PRODUCT

- ✓ Disconnect all electrical power to the machine.
- ✓ Make sure the machine cannot operate during installation.
- ✓ Follow all safety warnings of the machine manufacturer.
- ✓ Read and follow all installation instructions.

INSTALLATION INSTRUCTIONS

Open Power Unit

1. Remove battery ground and secure to prevent unintentional contact.
2. Attach oil line to pressure Switchgag. Use sealant tape or pipe dope.
CAUTION: Do not allow sealant to plug pressure Switchgag orifice.
3. Feed wire harness through bottom 2 in. (51 mm) dia. hole in bracket.
4. Feed oil line through upper 2 in (51 mm) dia. hole in bracket.
5. Install panel onto mounting bracket and secure.
6. Install oil line into engine oil galley. Use sealant tape or pipe dope.
7. Install temperature sensing bulb into water jacket.
CAUTION: Be sure capillary tube is routed away from exhaust manifold.
8. Connect wire 7A to hot terminal of fuel solenoid.
9. Connect wire 8A to engine block (ground).
10. Mount starter solenoid (auxiliary magnetic switch) to bracket 30050670 and mount assembly to engine below starter.

11. Connect wire 11B to starter terminal "S".
12. Connect wires 6A, 9B, and 10B to starter terminal "Bat".
13. Connect wire 10A to either of the large terminals on starter solenoid (auxiliary magnetic switch). Connect wire 11A to other large starter solenoid terminal.
14. Connect wire 5A to either of the small terminals on the starter solenoid. Connect wire 13A to the other small terminal.
15. Connect plug (wires 1A, 4A, and 12A) to alternator.
16. Connect wire 9A and 12B to battery terminal on alternator.
17. Be sure all connections are tight and reconnect battery ground cable.
18. Service engine according to manufacturer's instructions.
19. To start engine, depress and hold red reset button on panel face (518PH magnetic switch) while cranking. Observe that oil pressure has been established and release reset button. If reset button "pops out" engine will stop. Refer to the 518PH installation operation instructions.

Closed Power Unit

1. Remove battery ground and secure to prevent unintentional contact.
2. Enlarge panel cutout on engine enclosure to fit hole pattern on panel face and expose full panel face.
3. Attach oil line to pressure Switchgag. Use sealant tape or pipe dope.
CAUTION: Do not allow sealant to plug pressure Switchgag orifice.
4. Attach Switchgag panel assembly to rear side of cutout.
5. Follow steps 7 through 19 for open power units.

Typical Wiring Diagram (all models)

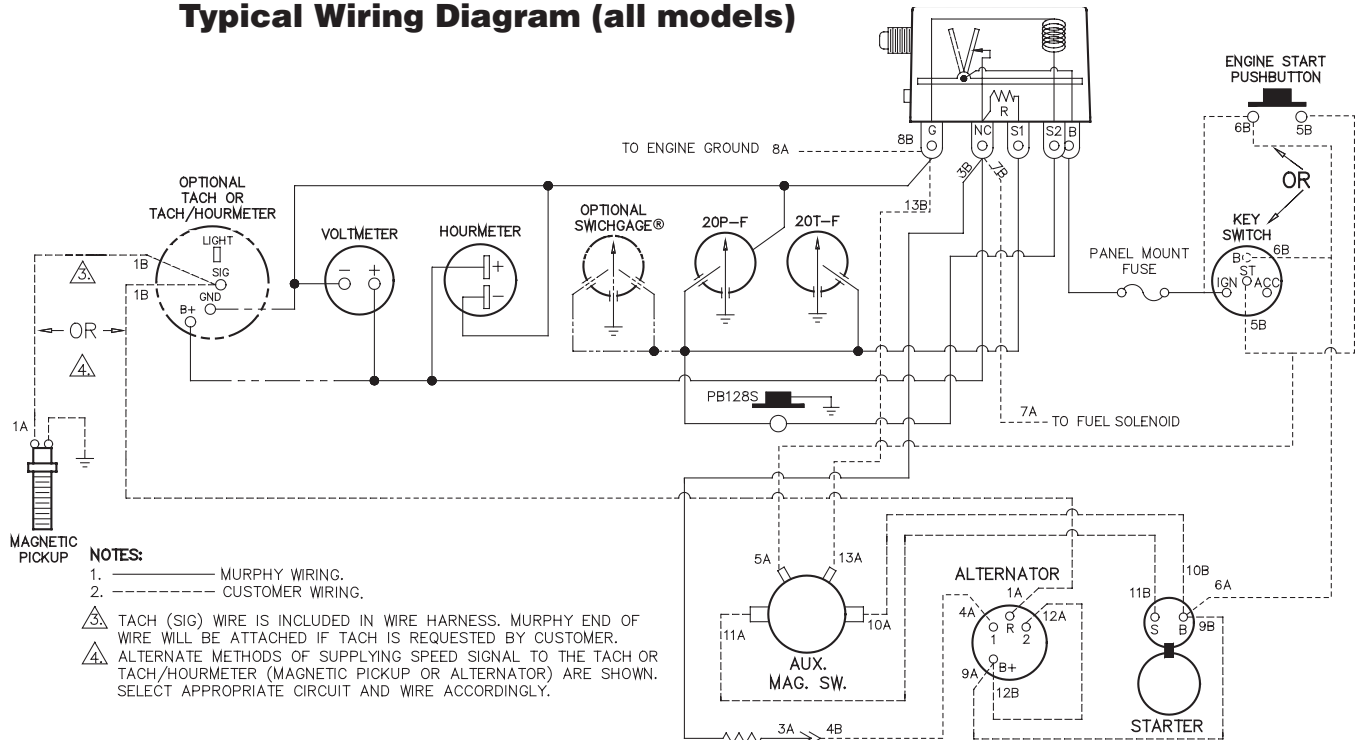

北京

信德迈科技(北京)有限公司 CNMEC Technology
 地址：北京市朝阳区安贞桥胜古中路2号金基业大厦201室
 邮编：100029
 *Tel: 010-8428 2935 | * Fax: 010-8428 8762
 *手机：139 1096 2635
 *电子邮件：sales@cnmec.biz
 主页：http://www.cnmec.com