

# Air Filter Restriction Swichgage®

VWC-7540B  
Revised 04-05  
Catalog Section 05



## VWC Series

- 2 in. (51 mm) and 2-1/2 in. (64 mm) dia. Water Column Swichgage for Detecting Restricted Dry Air Filters.
- Indicating Gage and Limit Switch in One.
- Use the Switch to Activate Alarms and/or to Shut Down Equipment
- Dependable and Accurate
- Dual Scale Reading
- Dash Mounting for Easy Viewing



### Description

The VWC Series Swichgage instruments are direct reading gages for use with dry air filters. As the filter deteriorates, air inflow will decrease creating increased vacuum between the air filter and the carburetor. The vacuum is monitored by the Swichgage instrument which gives a visual read-out of the filter condition. A built-in adjustable limit contact can operate an alarm to alert the operator when it is time to service or replace the air filter element. Murphygage indicating-only instruments are also available.

20VWC and 25VWC models feature a steel case and are available with dial illumination. The A25VWC model has a glass filled polycarbonate case. Standard models have a range of 0 to 30 in. (0-76 cm) of water restriction. Optional 0-50 in. (0-1.27 m) range is available. Please consult your engine operators manual for the recommended restriction limit for dry air filter servicing.

### Applications

The VWC Series Swichgage instruments can be used on any type of dry air filters for Gasoline or diesel engines.

They are particularly useful for engines operated in dusty environments such as agricultural and construction equipment, industrial engines and mobile equipment. Unlike traditional pop-up or latch-up type indicators, the VWC Series gives constant readout in meaningful terms of the changing condition of your filter.

### Specifications

Ranges Available (H <sub>2</sub> O Vacuum)	Contact Setting
0-30 in. (0-76 cm)	20 in. (508 mm)
0-50 in. (1.270 m)	40 in. (1.016 m)

**Contact Rating:** 2 A @ 30 V AC/DC.

**Contact Adjustment:** Allen head.

**Wire:** 18 AWG x 12 in. (1.0 mm<sup>2</sup> x 305 mm), (#4 screw on A25VWC)

**Dial:** White on black.

**Clamp:** Metal.

**Mounting hole:**

20VWC: 2-1/16 in. (52 mm).

25VWC/A25VWC: 2-11/16 in. (68 mm).

**Maximum panel thickness:** 1/4 in. (6 mm)

**Port:** Brass 1/8-27 NPT.

**Bezel:** Stainless steel.

**Case:** 20VWC and 25VWC: *plated steel*.

A25VWC: *glass filled polycarbonate*.

**Lens:** Polycarbonate.

**Mounting Studs:** 10-32 UNF.

**Calibration:** ± 3 in. (76 mm) H<sub>2</sub>O across scale.

**Unit Weights:** 20VWC: 8 oz (249 g).

25VWC: 10 oz (311 g).

A25VWC: 10 oz (311 g).

**Unit Dimensions:**

20VWC: 3 x 2-3/4 x 2-3/4 in. (76 x 70 x 70 mm).

25VWC and A25VWC: 4-3/4 x 4-3/4 x 3-1/4 in. (121 x 121 x 83 mm).

### Warranty

A limited warranty on materials and workmanship is given with this FW Murphy product. A copy of the warranty may be viewed or printed by going to [www.fwmurphy.com/support/warranty.htm](http://www.fwmurphy.com/support/warranty.htm)

### Dimensions

#### 20VWC Series

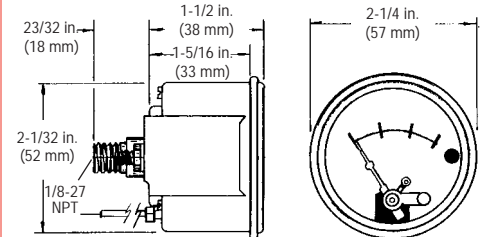

#### 25VWC Series

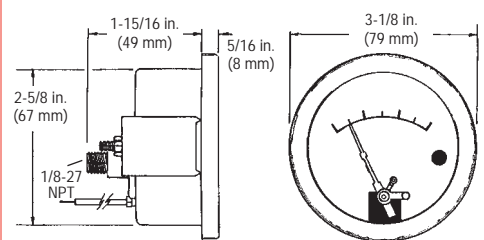

#### A25VWC Series

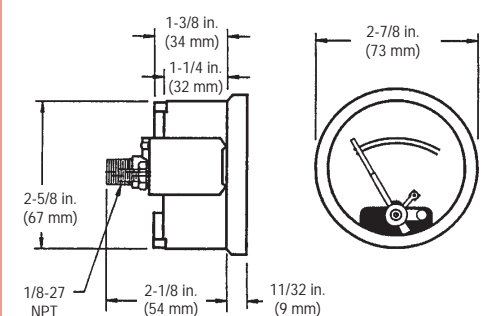

\* Products covered by this bulletin comply with EMC Council directive 89/336/EEC regarding electromagnetic compatibility except as noted.



# How to Order

To order, use the diagram below. List options in ascending alphabetical order (A-Z). Example: **20VWC-I-50**.

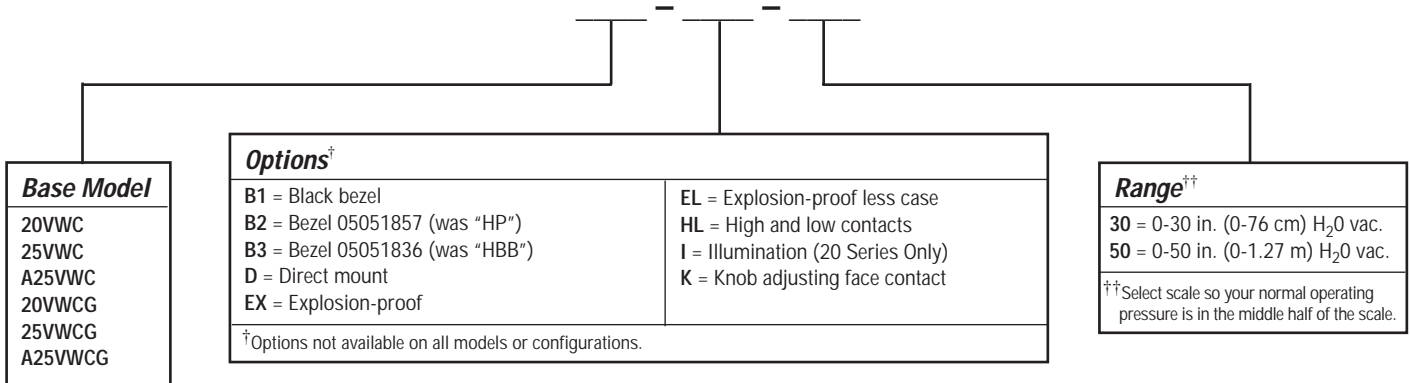

## Installation Instructions

WARNING

**Before beginning installation of this Murphy product:**

- ✓ Disconnect ALL electrical power to the machine.
- ✓ Make sure the machine CANNOT operate during installation.
- ✓ Follow all safety warnings of the machine manufacturer.
- ✓ Read and follow all installation instructions.

Murphy VWC-series air filter restriction gages are designed for either direct or dash mounting. A 1/8-27 male pipe thread is provided on the back of the case for the vacuum connection line. The electrical connecting wire is 18 AWG x 12 in. (1.0 mm<sup>2</sup> x 305 mm) long or #4 screw.

- A flexible section is essential at some point in the vacuum connecting line for elimination of vibration.

CAUTION: Mount gage away from engine vibration.

- The vacuum connecting line from the gage should be tapped into the engine air intake system between the air cleaner and the engine on a naturally aspirated engine, and between the air cleaner and blower on a turbocharged engine.
- When used on a carbureted engine, the vacuum line should be tapped into the engine air intake piping between the air cleaner and the carburetor.

CAUTION: Do not connect below the carburetor.

- Either of these installations will provide the equipment operator a direct reading of the restriction to airflow for the entire air induction system.
- A lower than normal reading indicates a ruptured intake line or a leaking connection, while a sudden, sharp increase in restriction indicates a collapsed filter or plugged intake system.
- When installing in an ungrounded panel provide a grounding wire from the Swichgage instrument to a common ground. Install only in a 12 or 24 V system. Make certain warning light or audible signal is same voltage as battery, and current draw does not exceed contact ratings of the Swichgage instrument. (A TL-7/mini-siren audible alarm is ideal for these applications.)

**NOTE:** Ordinary incandescent lights are damaging to the Swichgage contact. Murphy TL-7 flashing lamp and/or SAH mini-siren are recommended.

### Typical Wiring Diagram

WARNING: Perform the wiring operation with the power source off.

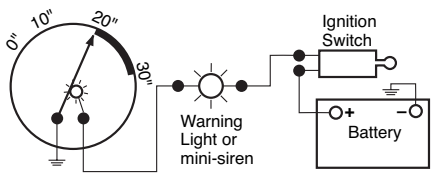

Murphy摩菲仪表授权经销商  
 信德迈科技(北京)有限公司 CNMEC Technology  
 地址：北京市朝阳区胜古中路2号金基业大厦201室  
 电话：010-8428 2935 13910962635  
 Http://www.cnmec.com Email:sales@cnmec.biz  
 传真：010-8428 8762

Printed in U.S.A 55011B.

In order to consistently bring you the highest quality, full featured products, we reserve the right to change our specifications and designs at any time.