

## Electronic Vibration Switch (EVS)



### Features

- Piezoelectric-crystal internal sensor with built-in microelectronics for reduced noise sensitivity
- Electronically integrated output signal that measures and trips on velocity
- Adjustable calibrated set-point controls
- Shutdown set-point measured in velocity
- 4-20 mA output for continuous monitoring capability
- Solid-state outputs for setpoint trip
- Adjustable time delay to prevent false tripping on high-vibration start-ups or non-repetitive transient events
- Self-test and calibration

**The Electronic Vibration Switch (EVS)** protects against equipment failure by monitoring velocity-based vibration levels and providing an early warning or shutdown when abnormal vibration is detected.

The EVS product can be connected to Murphy's TTD™ annunciator, Centurion™ or Millennium™ controllers for increased functionality. It also complements Murphy's VS2™ switch, which is designed to detect an abnormal shock or excessive vibration due to equipment failure and to shutdown other equipment in a system to prevent further damage.

**NOTE:** For proper operation, refer to document "00-02-0744 - EVS Installation and Operations Manual".

The EVS product can be used on any equipment where abnormal vibration could lead to equipment damage, including:

- Cooling fans
- Engines
- Pumps
- Compressors
- Gear boxes
- Motors
- Generator sets

The EVS product can monitor and alert the operator of abnormal vibration caused by a variety of possible factors, including:

- Imbalance and misalignments
- Worn sleeve bearings
- Broken tie down bolts
- Worn ball or roller bearings
- Gear mesh
- Blade pass frequencies
- Detonation
- Broken parts

### How to Order

A=Analog (24VDC external power, switch and 4-20mA output)

S=Standard (24VDC external power, switch only)

## Product Dimensions and Sensitivity Axis

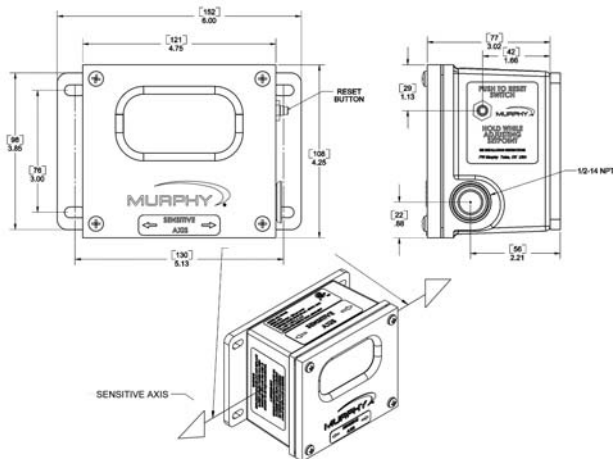

## Specifications

### Environmental

- Operating Temperature: -40°F to 185°F (-40°C and +85°C).
- Humidity: 0-95% non-condensing
- Vibration: 30 g's (Mechanical stability)

### Power Requirements

#### **Murphy EVS-A, EVS-S – External DC Power**

- External power: 8-32 VDC
- Input Current: 100mA Max

### Product Accuracy

- $\pm 5\%$  of full scale at 1.5 ips and 21 deg C.
- $\pm 5\%$  Variation over temperature from 21 deg C, over operating range.
- Integration Stage End-to-End Noise: <0.01 ips RMS

#### **Murphy EVS-A and EVS-S**

- $\pm 5\%$ , at Bandwidth of 6 to 500 Hz from 50Hz calibration point
- $\pm 3\text{dB}$  at Bandwidth of 3 to 875 Hz, worst case

### Trigger Feature

- Trigger level between 0.1 and 1.5 inches per second (ips) Peak
- Trigger set with single turn adjustable PC board mount potentiometer
- PC board marked with 15 marks corresponding to 0.1 to 1.5 in 0.1 increments

### Time Delay Feature

- Adjustable from 0 to 10 seconds
- Set with adjustable single turn PC board mount potentiometer
- PC board marked with 11 marks corresponding to 0 to 10 seconds in 1 second intervals

### Output

- Normally-Open and Normally-Closed outputs simultaneously available
- Open-collector outputs sink to Common Ground
- 50 mA sink capacity
- Input voltage: 40 VDC maximum
- Switch output is selectable for latched or non-latch configurations. Reset accomplished by reset pushbutton or external contact closure when in latch mode.
- Shutdown Alarm activated on power loss

### LED Outputs

#### **Alarm LED output**

- Red LED
- LED strobing for first 5 minutes after entering Alarm mode
- Flashing thereafter until Reset activated
- Strobe rate: 2mSec on, every  $0.5 \pm 0.25$  seconds
- Flash rate: 2mSec on, every  $6 \pm 1$  seconds

#### **Power LED output**

- Green LED
- Flash Duration: 2mSec

#### **Murphy EVS-A and EVS-S**

- Flash once every  $6 \pm 1$  seconds

#### **4-20mA output (EVS-A only)**

- Power obtained from power supply
- Loop Resistance: 600 ohms max at 24 V and 20mA.
- Current loop accuracy  $\pm 5\%$  from internal setpoint
- 20 ma corresponds to 1.5 ips Peak
- 4 ma corresponds to 0 ips Peak

### Reset

- Local reset switch w/momentary contact
- External reset: Available via header and will require an external relay or pushbutton contact to ground to activate the reset.
- Activation Period: Reset must be active for 0.5 sec. minimum to reset the switch.

### Circuit Functional blocks

#### **Charge Amp interface Band-aids Filter Integration**

- The input Transducer is an integrated PZT element for measuring acceleration with an internal charge converter.
- Maximum G level of 13 g's at 500hz

#### **Band-aids Filter**

- Frequency response dependent on model number (refer to "Product Accuracy")

### Integration

- Integration to convert from G to IPS peak

Murphy摩菲仪表授权经销商：

信德迈科技(北京)有限公司CNMEC Technology (Beijing) Co.,Ltd.

地址：北京市朝阳区胜古中路2号金基业大厦201室 邮编：100029

电话：010- 8428 2935, 8428 9077, 13910962635

Http：//www.cnmec.com

Email: sales@cnmec.biz

传真：010-8428 8762

**Warranty** - A limited warranty on materials and workmanship is given with this FW Murphy product.

A copy of the warranty may be viewed or printed by going to <http://www.fwmurphy.com/warranty>