

4.5 in. (114 mm) Dial Temperature Switchgauge® SPL and 45TE Series



Features

- Combination Indicating Gage and Critical Temperature Limit Switches
- High and Low Temperature Limit Contacts Are Visible and Adjustable
- SPDT Snap-Acting Models
- Panel and Wall Mount Versions
- Latching Control Relay Versions Available



- 1 Products covered by this bulletin comply with EMC Council directive 89/336/EEC regarding electromagnetic compatibility except as noted.
2 Selected configurations are third party listed. Call Murphy for details.

The 4-1/2 in. (114 mm) dial size Switchgauge® is a mechanical gage for temperature indication. It includes adjustable, electrical contacts that can be used for start and stop, to trip alarms and to shut down equipment.

Ranges are available from 15° to 250°F (9° to 121°C) thru 260° to 450°F (127° to 232°C).

Basic Operation

This vapor actuated gage features a sealed capillary tube and sensing bulb. When subjected to heat, the liquid in the sensing bulb expands to vapor creating pressure against a bourdon tube mechanism. The bourdon tube translates this vapor pressure into a mechanical gage reading.

For models SPLC and SPLFC, the gage pointer acts as a pressure indicator and as one switch pole which completes a circuit when it touches the adjustable limit contacts. Contacts have self-cleaning motion to ensure electrical continuity. A toggle switch is provided on SPLC models to override the low contact for equipment start-up.

Models 45TE and 45TEF have internal snap-acting SPDT switches.

Applications

Typical applications include:

- Gas Compressors
- Engine Coolant Temperature
- Process Temperature
- Heaters and Coolers
- Water Pump Temperature

Specifications

Dial: White on black, dual scale, °F and °C standard, 4-1/2 in. (114 mm) diameter.

Case: Die cast aluminum, surface or panel mount.

Capillary: PVC armored copper tube, 5 ft. long (1.5 m.) standard—see options next page.

Sensing Bulb: Copper bulb: 1/2 in. (13 mm) OD; Length: 7 in. (178 mm).

Minimum bulb insertion— see corresponding chart, on page 2.

Pressure Rating: 600 psi (4.1 MPa) [41 bar]. Connection: 1/2 NPT compression fitting.

Overrange: Do not exceed 10% above full range.

Limit Contacts (SPLC and SPLFC): 1-SPDT, Center off; pilot-duty; 2 A @ 30 V; 1 A @ 125 VAC. Contacts are gold plated silver.

Snap-Acting Switches (45TE and 45TEF): 2-SPDT; 2 A @ 250 VAC.

Dry Relay Contact ("BP" Models): 10 A @ 28 VDC or 10 A @ 120 VAC.

Wire Connections: Surface mount models: 1/2 NPT conduit and terminal block.

Panel mount models: Wire leads, 18 AWG (1.0 mm²) x 9 in. (229 mm) long.

"OS" models: 1/2 NPT conduit and wire leads, 18 AWG (1.0 mm²) x 9 in. (229 mm) long.

Item Weight: 8 lb. (3.6 kg) approximately. Explosion-proof models: 22 lb. (10 kg) approx.

Item Dimensions: 16 x 11 x 5-1/2 in. (406 x 279 x 140 mm).

Explosion-proof models: 12 x 12 x 9 in. (305 x 305 x 229 mm).

Basic Models

SPLC Series Switchgauge®

Surface mount version of the Switchgauge®. For these models the gage pointer makes with two adjustable contacts to complete a pilot duty circuit.

SPLFC Series Switchgauge®

Panel-mounting (round case) version of the SPLC.

SPLBP Latching Control Relay Switchgauge®

This version of the SPLC Series is designed to start and to stop electric motor driven equipment. The pilot duty contacts of the SPLBP are connected to a latching control relay for automatic ON/ OFF control, either directly or through a motor starter.

45TE Series Snap-Acting Switchgauge®

Surface mount version of the Switchgauge®. These models offer internal snap-acting SPDT switches, instead of the single pole contacts.

45TEF Series Switchgauge®

This is the panel mounting (round case) version of the 45TE series.

45TEBP Snap-Acting and Latching Control Relay Switchgauge®

Same as 45TE—includes an internal latching control relay for automatic ON/OFF control either directly or through a motor starter.

Murphy offers square case configurations altered to fit round panel openings, see "Dimensions", next page.

Dimensions

Surface Mount Models

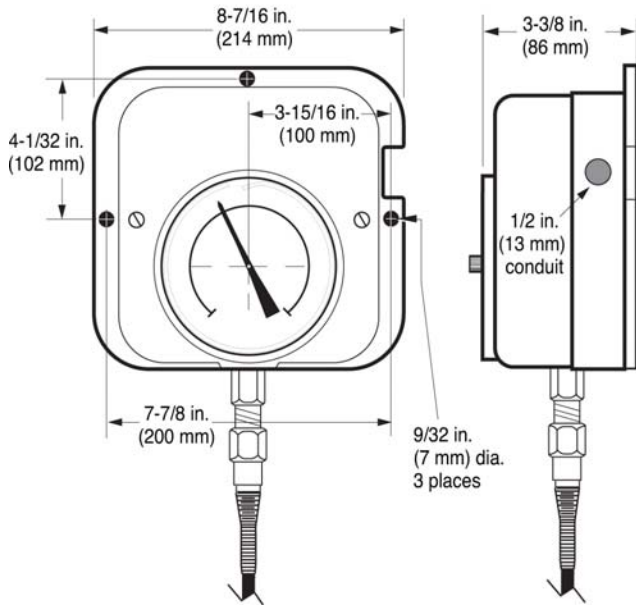

* SPLCE, SPLBPE, 45TEE and 45TEBPE versions feature square case, but altered to fit standard round panel mounting—not pictured.

Panel Mount Models

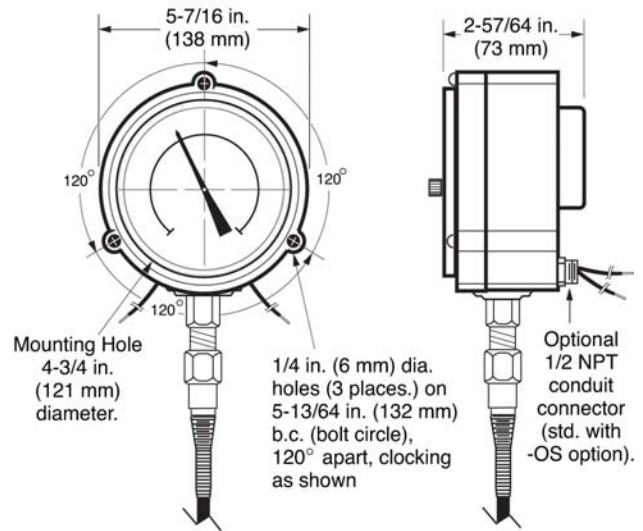

Sensing Bulb

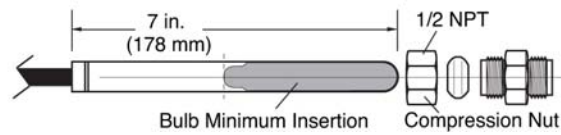

Ranges and Accuracy — Sensing Bulb Insertion

Temperature Ranges Available (dual scale dials)		Accuracy (SPL and 45 Series Models)			Minimum Sensing Bulb Insertion into Process
Fahrenheit	Celsius	First 1/3	Middle 1/3	Upper 1/3	
15° to 250°F	9° to 121°C	±8°F/±4°C	±2°F/±1°C	±2°F/±1°C	5 in. (127 mm)
130° to 350°F	54° to 177°C	±8°F/±4°C	±2°F/±1°C	±3°F/±1.5°C	2-1/2 in. (64 mm)
260° to 450°F	127° to 232°C	±8°F/±4°C	±2°F/±1°C	±3°F/±1.5°C	2-1/2 in. (64 mm)

Using a Thermowell

Installing a thermowell is recommended for high pressure applications or corrosive environments. It also allows sensing bulbs to be changed or adjusted without opening the connection to process. Murphy offer thermowells for a variety of applications. For details see Murphy bulletin T-9003B.

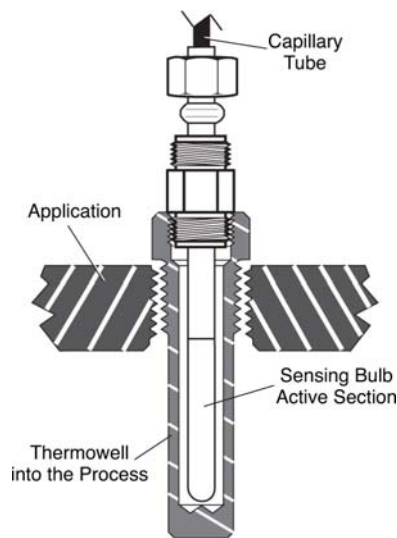

Start-Up Lockout

The SPLC Switchgag® low limit contact can be bypassed for equipment start up. A toggle switch is provided for this purpose. The toggle switch must be manually reset when temperature rises above the low limit.

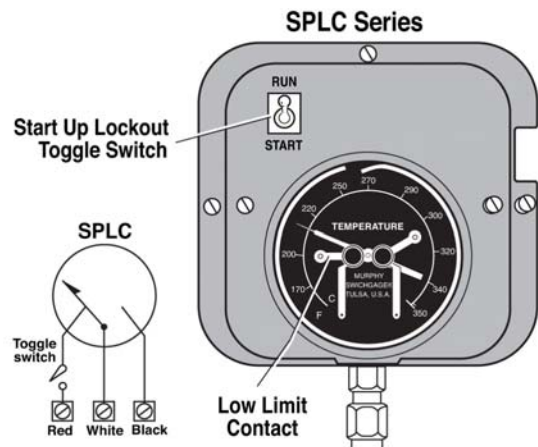

How the SPL Works

SPLC and SPLFC Swichgag[®] temperature indicator gages include 2 pilot duty, pointer-type limit contacts (one for high and one for low) that can be used for alarm and/or shutdown. The SPLC and SPLFC models will complete a circuit when the gage pointer and either limit contact meet. This provides an electrical signal to alert the operator of critical temperature conditions or, when required, to shut-down the equipment. Both limit contacts (high and low) are field adjustable by simply turning the fingertip type knob to the desired point on the scale dial.

The graphic below shows details of a typical SPLFC Swichgag[®] model.

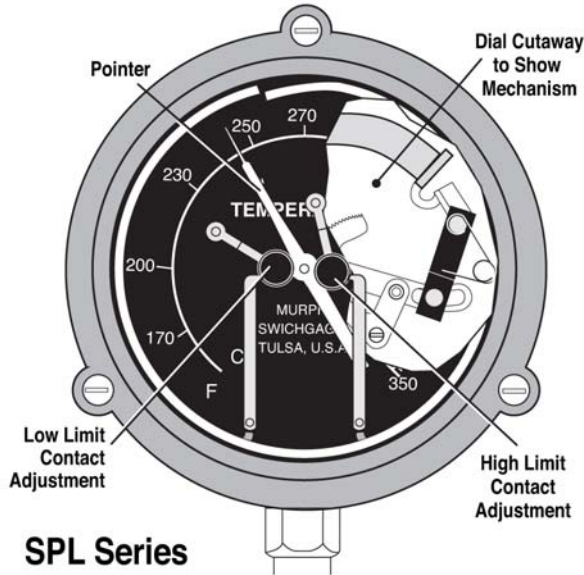

How the 45TE Works

The 45TE series Swichgag[®] incorporates 2 SPDT snap-switches instead of the pointer-type contacts of the SPL. Unlike the SPL that completes an electrical circuit as soon as the pointer touches the contact, the 45TE trip point indicators will stop the pointer movement slightly before the switches operate. As temperature continues to increase (reaching high set point) or to decrease (reaching low set point), the electrical circuit is then made. It provides the ability to set the trip point exactly with the indicator needle—no guessing or equipment calibration is needed as on blind switches. The 45TE trip points (high and low) can be easily set using its stacked knob adjustment. See the schematic below for details.

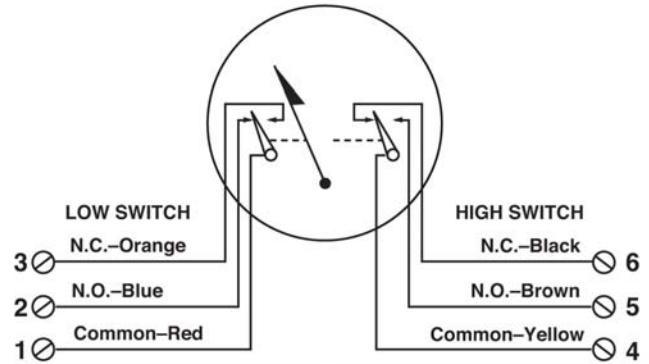

(BP) Latch Relay Contact Models

Primarily designed to maintain a specific temperature range by turning ON or OFF heaters or coolers having 125 VAC circuitry, the SPLBP and 45TEBP Swichgag[®] models are applicable to a variety of situations where temperatures are variable and controlling factors. As the pointer touches a preset high or low limit contact/snap-switch, the magnetic latching relay sets or resets to latch a heater or cooler ON or OFF. The relay unlatches, (resets) when the opposite contact operates. Pictured below is a typical application. **For applications with higher voltages, a Murphy TR assembly can be used in conjunction with any 4-1/2 in. (114 mm) dial Swichgag[®].**

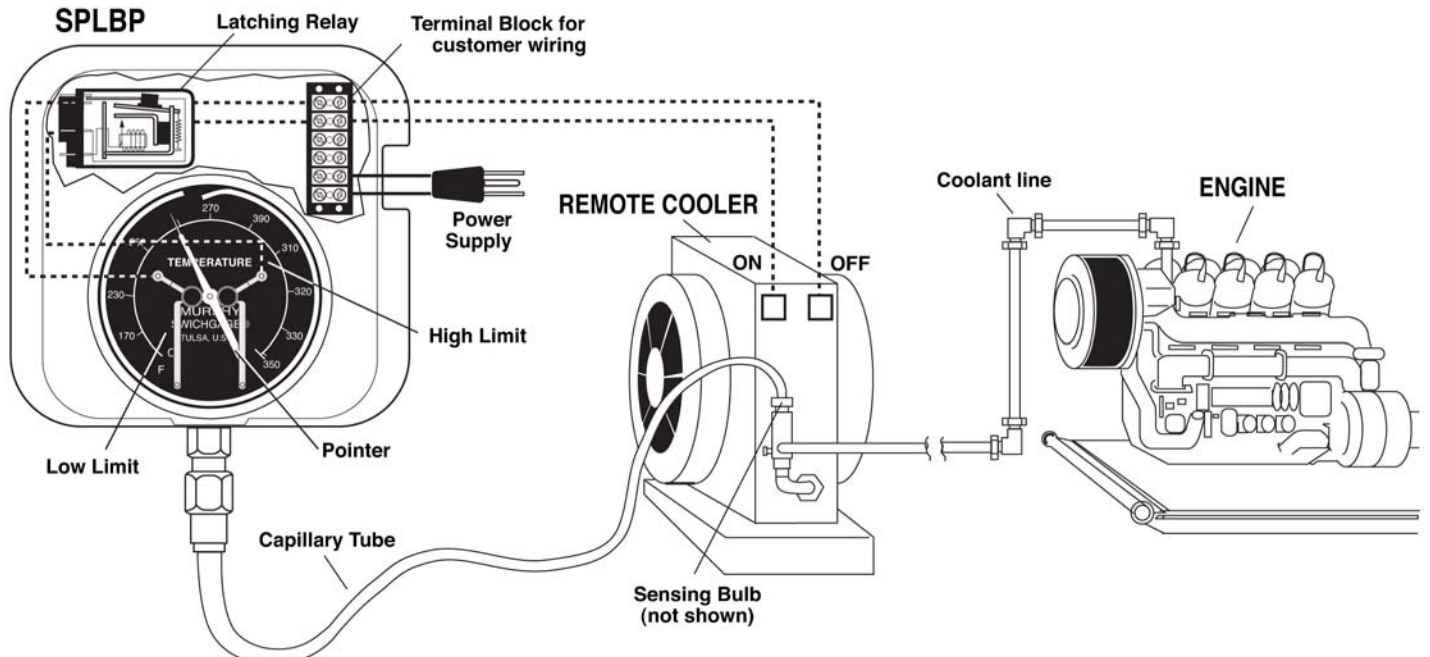

How to Order

Specify model number. NOTE: No designator is required for **Standard** configurations.
Also, list options in alphabetical order (A to Z). Place a dash (-) between each option. See example below.

SPLBP - 4 - 350 G 10 - EX

Base Model	
SPLC	45TE
SPLCE	45TEE
SPLFC	45TEF
SPLBP*	45TEBP*
SPLBPE*	45TEBPE*

* This version not covered by CE mark.

Latching Control Relay Voltage (applies to "BP" models only)
Blank = 120 VAC
2 = 12 VDC
4 = 24 VDC

Range
250 = 15 to 250°F
350 = 130 to 350°F
450 = 260 to 450°F

Armor / Capillary / Bulb
P = PVC / Copper / Copper
S = Stainless steel / Stainless steel / Stainless steel

Capillary Length	
Specify in feet:	Specify in metres:
05 = 5 feet	1.5M = 1-1/2 metres
10 = 10 feet	2M = 2 metres
Etc.	Etc.
5 ft. increments available to 30 ft., thereafter 10 ft. increments only. Some ranges are not available over 50 ft.	

Options
NOTE: Verify option availability. Not all options can be provided for every model.
BC = Capillary tubing exits from back of case
ES = Environmentally sealed for isolation from the elements
EX = Explosion-proof; SWICHGAGE® enclosed within explosion proof case; Class I, Division 1, Groups C & D
EL = (EXLC) Explosion-proof less case; internal gage mechanism only—without case
LC = Less case; SWICHGAGE® mechanism and hardware connections—without case
OS = Liquid filled case for resistance against corrosion, environment, vibration and electrical arc
TA = (TCA) Tickler contact; includes 1 auxiliary contact (tickler) and 2 limit contacts (all-face-adjustable-SPL series)

Tamperproof Contact Accessory

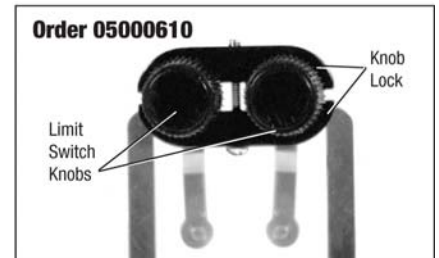

MURPHY摩菲仪表授权经销商

CNMEC Technology (Beijing) Co.,Ltd.
信德迈科技(北京)有限公司
地址：北京市朝阳区胜古中路2号金基业大厦201室
邮编：100029

电话：010- 8428 2935, 8428 9077
Http：//www.cnmec.biz
Email: sales@cnmec.biz
传真：010-8428 8762