



Model Series MDTM89, Dual Temperature Gauge

Installation and Operations Manual

* When used with approved Ignitions or 12-24 VDC

** Approved for CD Ignition, 80-250 VDC

Warranty - A limited warranty on materials and workmanship is given with this Murphy product. A copy of the warranty may be viewed or printed by going to <http://www.fwmurphy.com/warranty>.



Please read the following information before installing.

BEFORE BEGINNING INSTALLATION OF THIS FW MURPHY PRODUCT:

- A visual inspection of this product for damage during shipping is recommended before installation.
- It is your responsibility to ensure that qualified mechanical and electrical technicians install this product.
- Disconnect all electrical power to the machine.
- Make sure the machine cannot operate during installation.
- Follow all safety warnings of the machine manufacturer.
- Read and follow all installation instructions.
- Please contact FW Murphy Production Controls immediately if you have any questions.

Table of Contents

General Information	3
Description.....	3
Mounting Dimensions	3
Wiring and Adjustment Information	4
One Thermocouple Only	4
Open Thermocouple Input	4
MDTM89 Wiring and Adjustment Instructions	4
Operation Test	5
Trip Point Adjustment Information	6
Trip Point Adjustments	6
Typical Wiring Diagram	6
Specifications	7

THIS PAGE INTENTIONALLY LEFT BLANK

General Information

Description

FW Murphy's model MDTM89 is an electronic, dual-temperature monitor. It monitors two thermocouples, displays the temperature of the thermocouple selected and has adjustable trip points for each input. A toggle switch provides for selection of the thermocouple to be displayed and/or the temperature trip point to be checked/adjusted. If either trip point is reached, the associated output turns ON and can be used as a control signal or to initiate alarms and/or shutdown.

Model	Power Source	Rating
LCDT	CD Ign., 120 VAC, 12/24 VDC	Cl.I, Div.1, Gr.D, Haz. Areas ¹
S1501	120 VAC or 12/24 VDC	Cl.I, Div.1, Gr.D, Haz. Areas
MARK TTD	CD Ign., 12/24 VDC	Cl.I, Div.2, Gr.D, Haz. Areas ²
TATTLETALE®	CD Ign., 120 VAC, 12/24 VDC	Non-Hazardous Areas

¹An isolation barrier is needed between the MDTM89 and an Annunciator rated for Class I, Division 1, Group D, Hazardous Areas.

²When used with approved ignition. Contact FW Murphy for details.

Mounting Dimensions

Mount the MDTM89 temperature gauge in a place where it will be protected from rain and splashing water. A minimum distance of 12 in. (305 mm) from any ignition coils or coil leads should be maintained. The MDTM89 flush mount case is intended for mounting in a flat panel .032 in. (1 mm) to .125 in. (3 mm) thick.

First, cut a 4-3/4 in. (121 mm) diameter hole and three 1/4 in. (6 mm) diameter fastening holes as shown below. Insert the gauge from the back side of the panel. Using the three 10-24 screws, included with the gauge, secure to the panel.

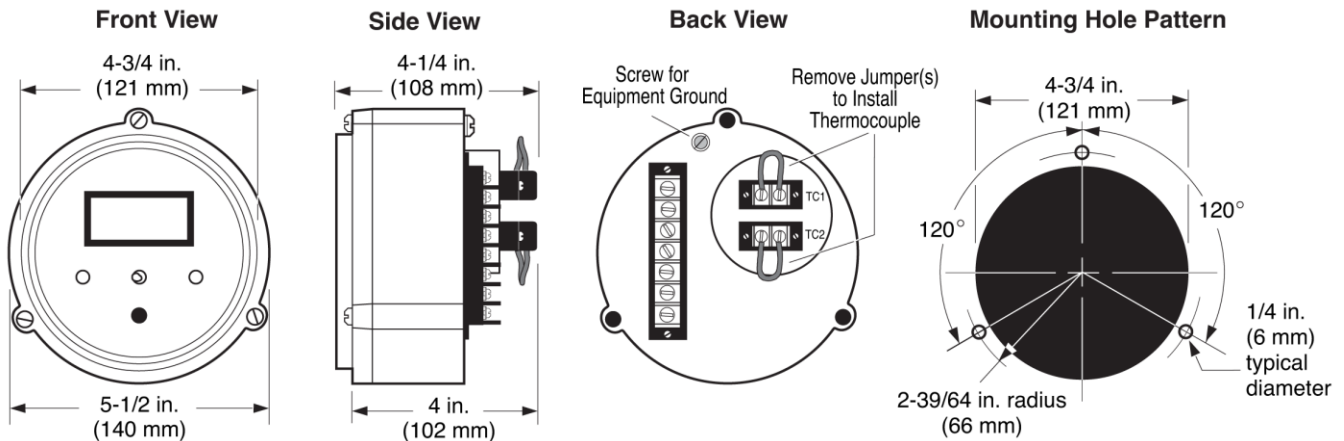

Wiring and Adjustment Information



CAUTION: Perform the wiring operation with the power source OFF. Make sure the voltage and current requirements are within the gauge ratings. Keep all high voltage wiring, such as spark plug wires, away from THERMOCOUPLES AND EXTENSION WIRING. Before wiring, determine the voltage and polarity for the application.

One Thermocouple Only

Even though the MDTM89 is a dual-temperature monitor, it will monitor and display one temperature with equal results.

When monitoring one temperature, always jumper the unused thermocouple terminals on the back of the MDTM89 with a short length of wire. The unused channel will display approximate ambient temperature.

Open Thermocouple Input

An open thermocouple input forces the monitor into upscale overrange. The monitor indicates an overrange by displaying the numeral 1 in the left most digit of the display. An overrange will turn on the trip point output for the respective thermocouple.

Table 1. Thermocouple Extension Wire Color Code

Thermocouple Type	Thermocouple Extension Wire	Color Code/Material	
		Positive Lead	Negative Lead
J	J	White/Iron	Red/Constantan
K	K	Yellow/Chromel	Red/Alumel

Table 2. Thermocouple Extension Wire Loop Resistance in Ohms per Foot at 68° F

Size AWG No.	Type J	Type K
14	.07	.146
16	.137	.230
18	.222	.374
20	.357	.586
24	.878	1.490

MDTM89 Wiring and Adjustment Instructions

Using Thermocouple Extension Wire

1. After thermocouple installation, connect the thermocouple leads to the MDTM89 according to the instructions.



IMPORTANT: Use correct wire for the thermocouple selected. USE ONLY THERMOCOUPLE EXTENSION WIRE.

2. If the thermocouple leads are not long enough, you will need to use shielded thermocouple extension wire. The thermocouple extension wires, from your thermocouple lead wires to the terminals of the MDTM89, must be of the same material as the thermocouple lead wires. See Table 1.



CAUTION: The use of non-thermocouple wire will cause inaccurate temperature sensing and erratic operation.

3. When connecting the thermocouple extension wire to your thermocouple leads, twist the wire connections, then install wire nuts, such as ceramic type, which have no metal insert. **DO NOT SOLDER.**
 - a. To prevent problems of interference from electrical noise, **DO NOT** route thermocouple wires in the same conduit or within 12 inches (304 mm) of ignition wires or alternating current conductors.
 - b. Metallic-overbraided thermocouple wire is recommended. It provides electrical shielding as well as protection against wear and abrasion.

Connecting Thermocouple Wires (ungrounded thermocouple)

1. Remove factory-installed jumpers or shunts from TC1 and TC2 terminals before connecting thermocouple(s).
2. Connect the thermocouple leads to the thermocouples. Observe lead polarity. See Table 1 for thermocouple extension lead color code and thermocouple polarity.

NOTE: Before continuing to the next step, decide which thermocouple is to be identified as TC1 and which is to be identified as TC2. A wire marker should be installed on each end of the thermocouple lead to identify TC1 and TC2.

3. Connect the positive lead of thermocouple TC1 to the positive (+) terminal of terminal strip TC1.
4. Connect the negative lead of thermocouple TC1 to the negative (-) terminal of terminal strip TC1.
5. Connect the positive lead of thermocouple TC2 to the positive (+) terminal of terminal strip TC2.
6. Connect the negative lead of thermocouple TC2 to the negative (-) terminal of terminal strip TC2.

Connecting Output Wires

1. Wire the gauge trip point outputs as shown in the typical wiring diagrams on the back of this page.
2. Connect the Power Wires as detailed below.
 - a. Determine the voltage and the polarity of the input power before attempting to connect the power leads to the MDTM89.
 - b. On CD ignitions, connect the shut-down lead to the MDTM89 ignition input as shown in the diagrams on page 6.

Operation Test

Perform the Operation Test after the MDTM89 is installed and wired appropriately.

1. Rotate the trip point potentiometers TC1 and TC2 clockwise until an audible click is heard or detente is felt. These are 12-turn potentiometers.
 - a. Start the engine or power up the monitor.
2. Set the display selector switch to the TC1 position to display the TC1 temperature. Note temperature reading for step 2b.
 - a. Depress and hold the Push to Read trip point push button to display the TP1 setting.
 - b. Rotate the TC1 trip point potentiometer counterclockwise until the display reading is equal to the temperature reading observed in step 2.
 - c. Trip point TP1 will turn on and trip the shutdown device or alarm; verify by observation.
 - d. Rotate the trip point potentiometer TC1 clockwise several turns to turn off TP1.
 - e. Reset alarm or shut down device.
3. Set the display selector switch to the TC2 position to display the TC2 temperature. Note temperature reading for step 3b.
 - a. Depress and hold the Push to Read trip point push button to display the TP2 setting.
 - b. Rotate the TC2 trip point potentiometer counterclockwise until the display reading is equal to the temperature reading observed in step 3.
 - c. Trip point TP2 will turn on and trip the shutdown device or alarm; verify by observation.
 - d. Rotate trip point potentiometer TC2 clockwise several turns to turn off TP2.
 - e. Reset alarm or shut down device.

Trip Point Adjustment Information

Trip Point Adjustments

1. Power up the temperature monitor by turning on power or by starting engine.
2. Set the display selector switch to the TC1 position.
3. Depress the Push to Read trip point push button to read trip point.
4. Rotate the trip point potentiometer TC1 until the display indicates the desired trip point temperature for TC1.
5. Set the display selector switch to TC2 position.
6. Depress the Push to Read trip point push button to read the trip point.
7. Rotate the trip point potentiometer TC2 until the display indicates the desired trip point temperature for TC2.

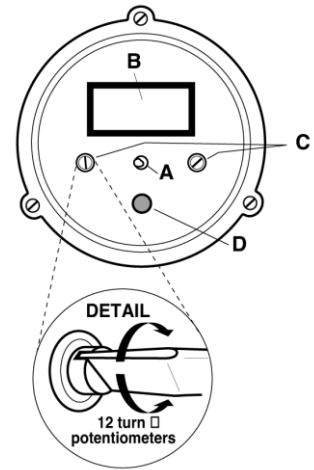

Typical Wiring Diagram

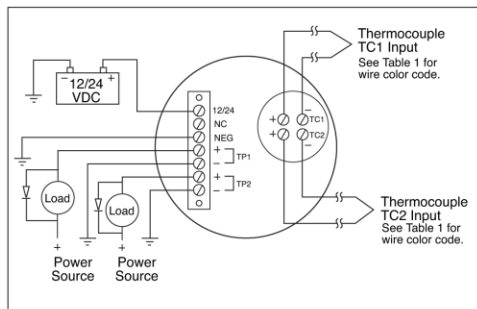

12/24 VDC Power

120 VAC Power
Option NOT approved by
CSA or Factory Mutual

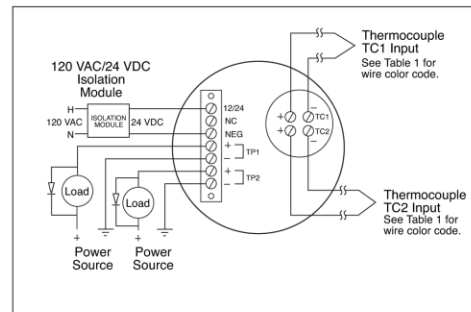

CD Ignition—Negative Ground

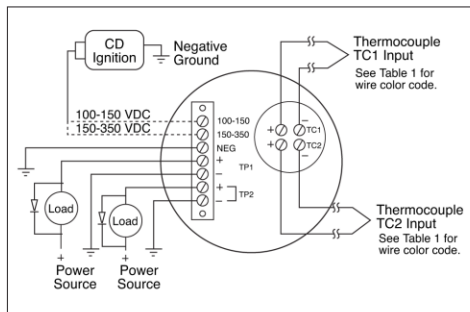

Typical TTD Hook-up

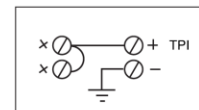

Specifications

Power Requirements (Operating Voltages):

MDTM89-A: 100 to 350* VDC, CD ignition, negative ground (FET outputs)

MDTM89-E: 100 to 350* VDC, CD ignition, negative grounds (FET outputs)

MDTM89-B: 100 to 350* VDC, CD ignition, negative or positive ground (SCR outputs)

MDTM89-C: 12 to 24** VDC, negative ground, 15 milliwatts (FET outputs)

MDTM89-D: 120 VAC (MDTM89-C with 120 V isolation module #IT-1) (FET outputs.) Model NOT approved by CSA or Factory Mutual

Power Consumption: CD ignition: 350 μ a @ 100V; 120 VAC: 0.6 watts; 24 VDC: 0.5 watts

Outputs:

Model B: Output turns on above trip point; output turns off when power is switched off; two (2) isolated SCR outputs, 0.5 amp @ 250 VDC

Models A, C and D: Output turns on above trip point; output turns off below trip point; two (2) isolated FET outputs, 0.5 amp @ 250 VDC

Model E: Output one turns on above trip point, output turns off below trip point: output 2 turns on below trip point, output turns off above trip point: two (2) isolated FET outputs, 0.5 amp @250 VDC

Ambient Cold Junction Compensation Range: 32° to 122° F (1° C from 0° to 50° C)

Operating Temperature: -4° to 158° F (-20° to 70° C)

Storage Temperature: -40° to 300° F (-40° to 150° C)

Case: Die-cast aluminum

Reset Differential: FET models: Decreases 3 Degrees (°F or °C)

SCR model: Turn input power off to reset

Measurement Range: Monitor Range 0°-1999° F or ° C (specify F or C in part number)

Accuracy: With J-type thermocouple: from 150°-1200° F (66°-649° C) \pm 1.5% of reading. With K-type thermocouple: from 400°-2000° F (204-1076° C) \pm 1.5% of reading. At calibration temperature.

Laboratory Approvals: CSA and Factory Mutual approved for Class I, Division 2, Group D, hazardous locations

Thermocouple Lead Length:

150 ohm lead resistance affects monitor accuracy less than 1°

Trip Point Accuracy: \pm 3° F (\pm 2° C) of reading

Trip Point Adjustment Range: 0-1999 Degrees

*When used with approved ignitions or 12-24 VDC. Contact FW Murphy for details.

**Approved for CD ignition, 80-250 VDC.

In order to consistently bring you the highest quality, full-featured products, we reserve the right to change our specifications and designs at any time. FW MURPHY product names and the FW MURPHY logo are proprietary trademarks. This document, including textual matter and illustrations, is copyright protected with all rights reserved. (c) 2017 FW MURPHY. A copy of our typical warranty may be viewed or printed by going to www.fwmurphy.com/warranty.

FW MURPHY PRODUCTION CONTROLS

SALES, SERVICES & ACCOUNTING
5417 S. 122ND E. AVE.
TULSA, OK 74146

CONTROL SYSTEMS & SERVICES
105 RANDON DYER ROAD
ROSENBERG, TX 77471

MANUFACTURING
5757 FARINON DRIVE
SAN ANTONIO, TX 78249

DOMESTIC SALES & SUPPORT

FW MURPHY PRODUCTS
PHONE: 918 317 4100
EMAIL: INFO@FWMURPHY.COM
WWW.FWMURPHY.COM

FW MURPHY CONTROL SYSTEMS & SERVICES
PHONE: 281 633 4500
EMAIL: CSS-SOLUTIONS@FWMURPHY.COM

INTERNATIONAL SALES & SUPPORT

CHINA
PHONE: +86 571 8788 6060
EMAIL: APSALES@FWMURPHY.COM

LATIN AMERICA & CARIBBEAN
PHONE: +1 918 317 2500
EMAIL: LASALES@FWMURPHY.COM

SOUTH KOREA
PHONE: +82 70 7951 4100
EMAIL: SKOREASALES@FWMURPHY.COM



FM 668576 (San Antonio, TX - USA)
FM 668933 (Rosenberg, TX - USA)



FM 523851 (China) *TS 589322 (China)*