

## PowerView™ PVM Series Gages



### Features

- For modern electronic engines and equipment using SAE J1939 Controller Area Network
- Display SAE J1939 parameters broadcast by the PowerView system
- Cutting edge, stepper motor technology and robust functionality combined
- Microprocessor driven for high accuracy
- Simple installation and wiring design

The **PowerView PVM Series Gages** are intelligent gages designed to display easy-to-read information transmitted by the PowerView. The PVM gages communicate with the PowerView via a single RS485 twisted pair MODBUS® RTU serial link. The gages can be daisy-chained using quick-connect harnesses.

The major feature of the PVM gages is their balance between design and functionality. These modern gages offer a selection of lens and bezel styles and colors.

The PVM gages also include features such as a smooth stepper motor operation for the 270° sweep pointer, an environmentally sealed case with two Amp Mini Universal Mate-N-Lok connectors molded into the casing, and green LED back lighting. They are available for standard 2-1/6" (52mm) and 3-3/8" (86mm) diameter hole sizes. In addition their plastic cases incorporate a "D" shape allowing panel cutouts that eliminate gage rotation during installation.

### PVM20 Series Models

- PVM20-A - Engine Oil Pressure
- PVM20-B - Coolant Temperature
- PVM20-C - Voltmeter
- PVM20-D - Percent Load at current RPM
- PVM20-E - Transmission Oil Pressure
- PVM20-F - Transmission Oil Temperature
- PVM20-G - Engine Oil Temperature
- PVM20-H - Hydraulic Oil Temperature
- PVM20-J - Percent Fuel Level
- PVM20-K - Boost Pressure
- PVM20-L - Exhaust Gas Temperature
- PVM20-M - Intake Manifold Temperature
- PVM20-N - Auxiliary Temperature
- PVM20-P - Auxiliary Pressure
- PVM20-T - Tachometer

### PVM35 Series Models

- PVM35-T - Tachometer
- PVM35-S - Speedometer

## Specifications

### PV101 Compatibility

- **Maximum supported:** 5 PVM Gages
- **Maximum distance to last gage:** 8.5 Meters

### Power Supply Input Voltage

- 5V (4.5-5.5 VDC minimum & maximum voltage)

### Power Supply Operating Current (@ 5 VDC) =

- PVM20, PVM35: 18 mA minimum; 80 mA maximum

### Backlight Maximum Current: 60mA

**Input:** RS485 MODBUS® RTU data.

**Output:** Analog Readout.

### Environmental

**Operating Temperature:** -40 to 185°F (-40° to 85°C)

**Storage Temperature:** -67 to 185°F (-55° to 85°C)

### Environmental Sealed Enclosure:

- Sealing: IP68, ±5 PSI (± 34.4 kPa)
- Case and Clamp Material: Polyester (PBT)
- Lens Material: Polycarbonate
- Bezel Material: Polyester (PBT)

**Dial:** White numerals over black background

**Return-To-Zero Needle Movement:** Not Available for PVM20 models.

**Indicating Pointer:** Stepper motor operation with 270° sweep

**Gage Accuracy:** Better than ± 1.0% of scale

**Maximum Panel Thickness:** 3/8 inch (9.6 mm)

### Connectors:

- Amp Mini Universal Mate-N-Lok
- Amp Plug P/N: 172338-1
- Amp Socket P/N: 171639-1

**Shipping Weight:** 1 Lb. (450 g.)

### Shipping Dimensions:

- 6 x 6 x 6 in. (153 x 153 x 153 mm)

## Typical Gage Dimensions

### PVM20 Series

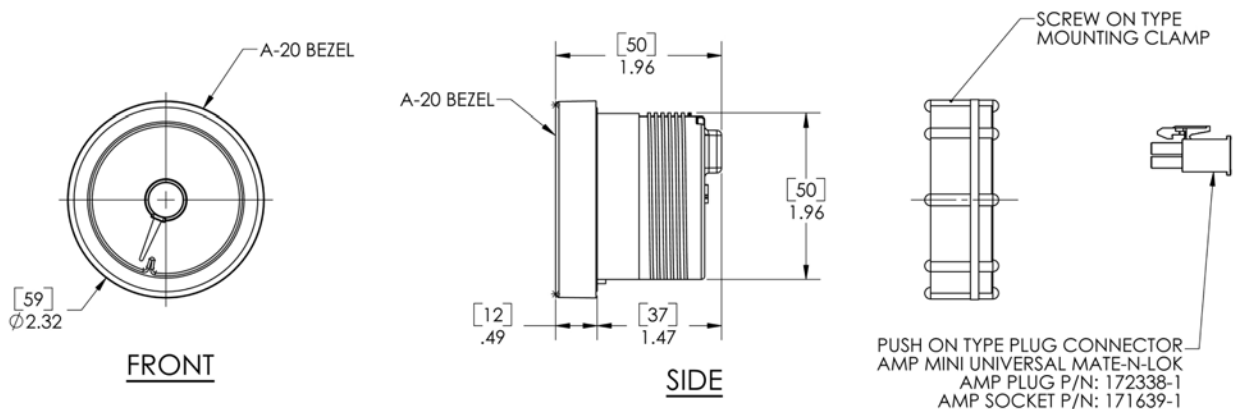

### PVM35 Series

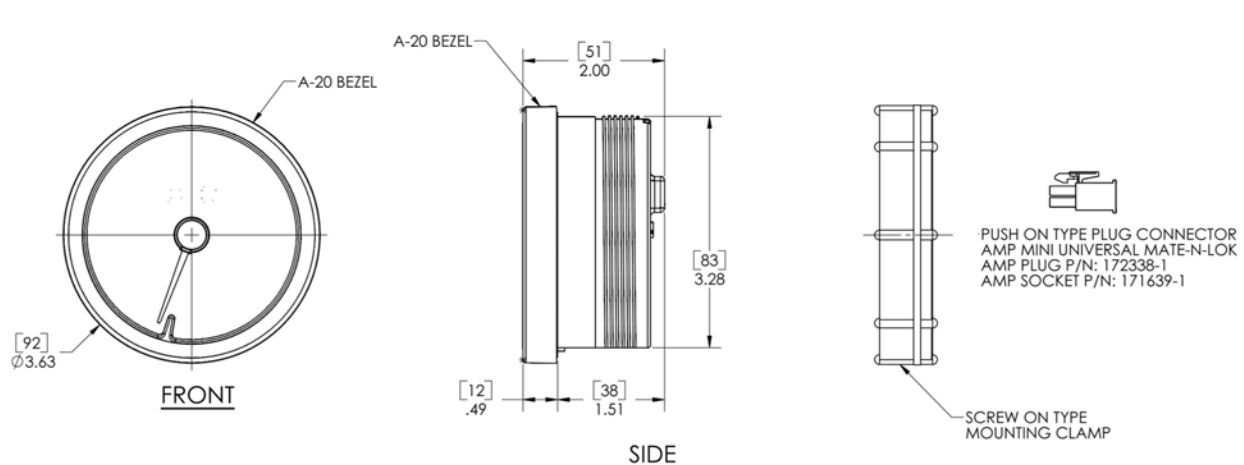

**Warranty** - A limited warranty on materials and workmanship is given with this FW Murphy product.  
A copy of the warranty may be viewed or printed by going to <http://www.fwmurphy.com/warranty>

## Bezel Styles

### PVM20 Series – 2 inch size gages

<b>AB</b> <b>A-20 Style</b>	<b>A</b> <b>A-20 Style</b>	<b>BB</b> <b>Low Profile SAE Style</b>
 	 	 

### PVM35 Series – 3-1/2 inch size gages

<b>AB</b> <b>A-20 Style</b>	<b>A</b> <b>A-20 Style</b>	<b>BB</b> <b>Low Profile SAE Style</b>
 	 	 

## How to Order

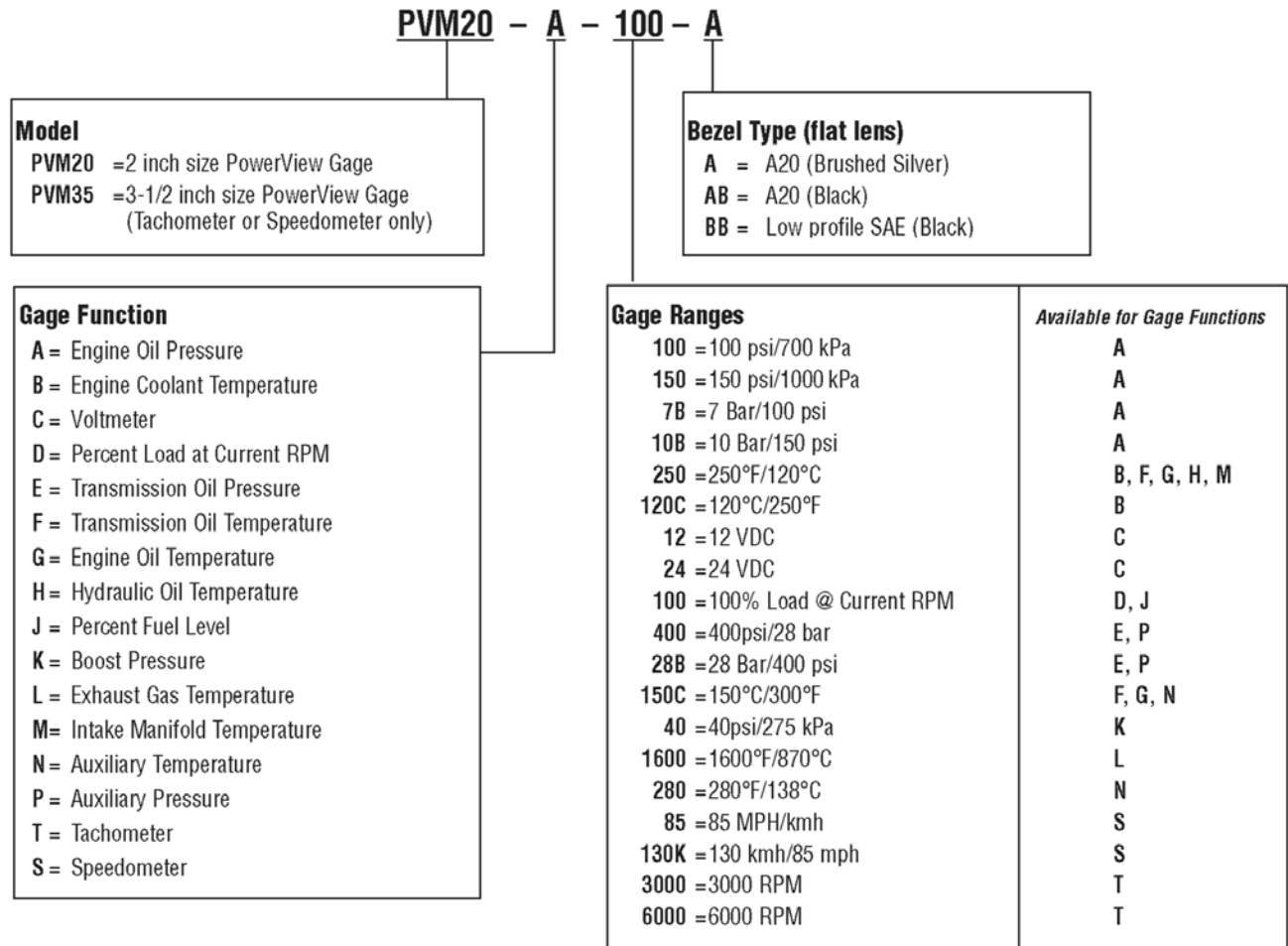

## Wiring Harnesses and Accessories

For details see bulletin "0710179 - Wiring Harness Accessories for PVM Gages"

MURPHY摩菲仪表授权经销商  
 CNMEC Technology (Beijing) Co.,Ltd.  
 信德迈科技(北京)有限公司  
 地址：北京市朝阳区胜古中路2号金基业大厦201室  
 邮编：100029

电话：010- 8428 2935, 8428 9077,  
 Http：//www.cnmec.com  
 Email: sales@cnmec.biz  
 传真：010-8428 8762