

Installation of Level Maintainers LM300 Series

LM300, LM301, LM302, LM303, LM304 and LM305 Models

The LM300 Series Level Maintainer automatically adds oil to the crankcase as needed to keep the lube level normal. Most models have built-in switches that will alarm and/or shut down the equipment if the makeup supply is depleted and engine oil level falls or if overfill conditions exist.

Although these instructions generally refer to an engine application, the LM300 can also be used with compressors, pumps and coolers.

Dimensions

Explosion-proof model dimensions shown. Non-explosion proof models are smaller in height and width — 7 in. (178 mm) H, 7-7/8 in. (200 mm) W.

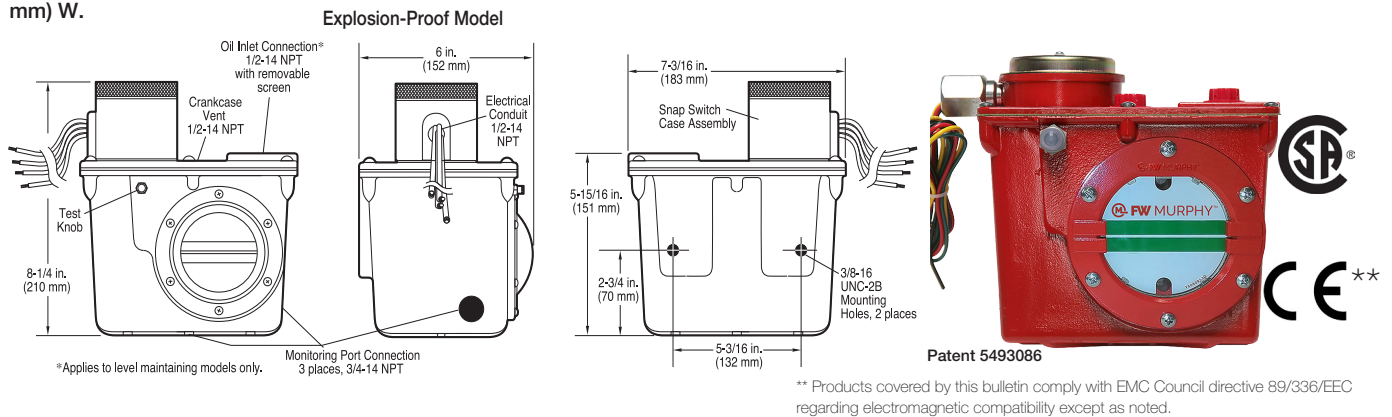

Installation

Please read the following instructions and warnings before installation. Visually inspect the product for any damage that may have occurred during shipping.

WARNING	Before beginning installation of this product:
	<ul style="list-style-type: none"> • Disconnect all electrical power to the machine • Make sure the machine cannot operate during installation • Follow all safety warnings of the machine manufacturer • Read and follow all installation instructions

Mounting The LM (Level Maintainers)

Install the Pipe or Universal Bracket with the installation method that best fits your application. Mount the LM as close as possible to the engine crankcase. Ensure the mounting brackets are well supported. Excessive vibration from poor mounting can cause overfill.

• Pipe Bracket

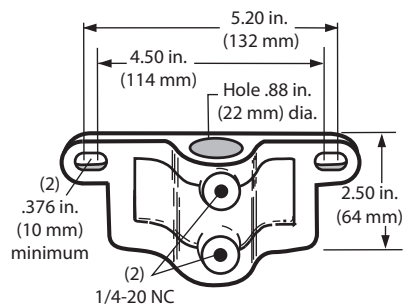

Pipe Bracket 15000371	
QTY	Description
2	Bolt, 3/8-16 UNC x 1 in.
2	Hex Nut, 3/8-16
2	Lock Washer, 3/8 I.D.
2	Flat Washer, 3/8 I.D.
2	Screw 1/4-20 x 1 in.
2	Lock Washer 1/4 in. I.D.
2	Hex Nut 1/4-20 x 7/16 in.

Deck Mounting With Pipe Bracket

1. Mount a nominal 1/2 inch (21 mm) diameter pipe (not supplied) to the deck of the engine in a predetermined location positioning the LM as close to the engine crankcase as possible.
2. Install the pipe bracket to the LM using two 3/8-16 UNC x 1 inch bolts with a nut, lock washer and flat washer (supplied).
3. Slip the LM bracket over the pipe. Install and temporarily hand tighten the two adjustment screws 1/4-20 UNC x 1 inch with a nut and lock washer (supplied). You will adjust the LM position later in the installation process.

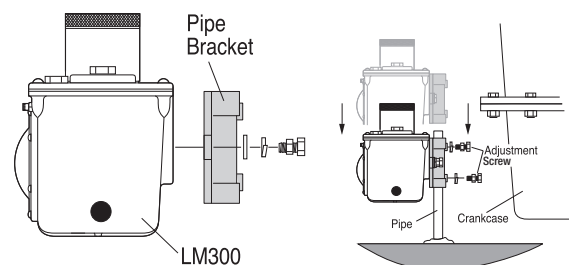

Mounting The LM ...continued

• Universal Bracket

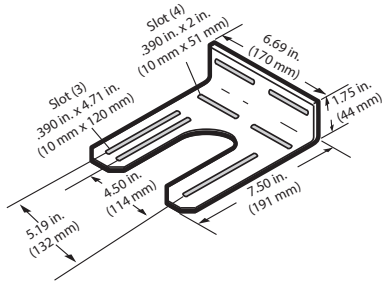

Universal Bracket 15000370

QTY	Description
2	Bolt, 3/8-16 UNC x1 in.
2	Nut, 3/8-16
2	Lock Washer, 3/8 I.D.
4	Flat Washer, 3/8 I.D.

Deck Mounting With Universal Bracket

1. Install the Universal Bracket to the deck of the engine in a predetermined location positioning the LM as close to the engine crankcase as possible. Secure the bracket with two flat washers (supplied) and two 3/8 inch diameter bolts (not supplied).
2. Mount the LM to the Universal Bracket, install and temporarily hand tighten the two adjustment bolts 3/8-16 UNC x 1 inch with a nut and lock washer (supplied). You will slightly adjust the LM position later in the installation process.

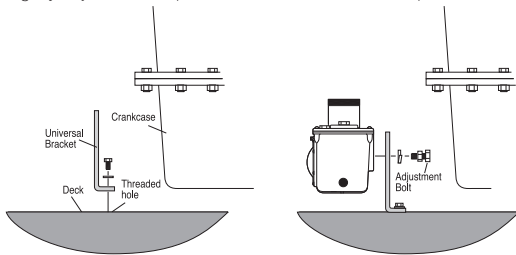

Engine Crankcase (Oil Pan) Mounting With Universal Bracket

- NOTE:** If space between the crankcase and mounting bracket is narrow, install the universal mounting bracket to the LM before installing to the crankcase oil pan.
1. Install the universal bracket to the crankcase using the existing crankcase bolts. Crankcase bolt diameter must be no larger than 7/16 inch (11 mm).
 2. Mount the LM to the Universal Bracket, install and temporarily hand tighten the two adjustment bolts 3/8-16 UNC x 1 inch with a nut and lock washer (supplied). You will slightly adjust the LM position later in the installation process.

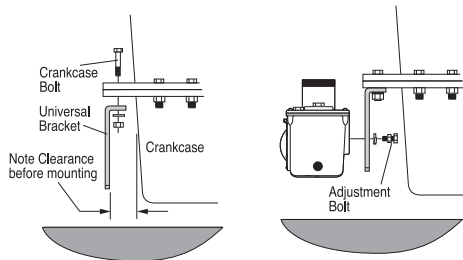

Install Fittings and Hoses

The following instructions are based on the Optional Hose Kit 15000355. If you did not order this kit, separately gather the hoses, clamps and fittings as specified below.

Optional Hose Kit 15000355

Qty	Description
1	1/2 in. (13 mm) I.D. x 3 ft. (914 mm) long hose
1	1 in. (25 mm) I.D. x 3 ft. (914 mm) long hose
2	1/2 in. (13 mm) worm gear clamp
2	1 in. (25 mm) worm gear clamp
2	1/2 NPT x 1/2 in. (13 mm) barbed fitting
2	3/4 NPT x 1 in. (25 mm) barbed fitting

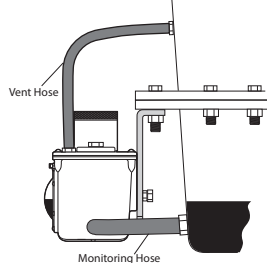

1. Apply Teflon sealant to the barbed fitting threads.
 2. Install a barbed fitting to the LM vent port and selected monitoring port.
- CAUTION:** Do not operate LM with shipping plugs in extra ports.
3. Apply Teflon sealant to threads of the supplied plugs and install them in the remaining monitoring ports if not used.

NOTE: Ensure engine oil is drained below access port used on crankcase.

4. Attach the 1 inch (25 mm) diameter, flexible monitoring hose with two worm gear clamps to the engine oil crankcase and the monitoring port on the LM.

CAUTION: The hose must slope slightly downward from the LM and **MUST NOT** have any droop or low spots.

NOTE: If the drain plug on the crankcase is used for the connection, we recommend installation of a tee to allow draining of the crankcase for service.

5. Install the 1/2 inch (13 mm) I.D. x 3 ft. (914 mm) hose with two worm gear clamps to the vent connection on the LM and to the vent connection on the crankcase. The vent connection on the crankcase must be well above the regulated oil level. All hoses must be clear of obstructions.
 6. Tighten worm gear clamps and verify hose connections are tight.
- IMPORTANT:** Do not over-fill or under-fill engine crankcase.
7. Fill the crankcase to the proper oil levels. With the engine running and warm, loosen the mounting bracket adjustment bolts and adjust the LM so that the oil level in the Viewing Lens is aligned with the White Index Line on the dial. Tighten the adjustment bolts.

Verify that hose clamps are tight and all connections are secure before filling the crankcase and starting the engine.

Ensure no oil leaks are present with engine running.

Move LM to Align engine oil with white index line on the dial.

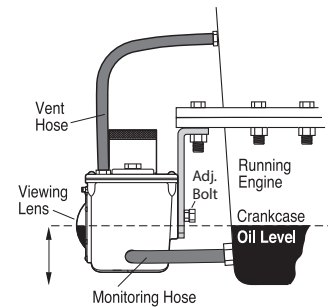

• Connecting to an Oil Supply Tank (Level Maintaining Models)

1. Remove the caplug from the oil inlet connection. Verify that the filter inside the connection is clear of debris. Install the oil inlet connection.
2. Connect a 1/2 inch I.D. (13 mm) or larger hose (not supplied) to the oil inlet fitting on the LM and to the shutoff valve on the oil supply tank with the following considerations.
 - a.) For models LM300 thru LM305: mount the oil supply tank above the LM at least 4 ft. (1.2 m) minimum; no more than 15 ft. (4.6 m) maximum.
 - b.) The hose must maintain a downward slope and not have low spots or droops.
 - c.) The maximum head pressure rating using standard 1/4 in. (6 mm) orifice is 15 ft. (4.6 meters). See **Flow Rate Test Chart** on last page for additional orifice pressure ratings.

WARNING: Overfill condition can be caused by excessive inlet pressure (max inlet pressure depends on orifice) and/or improper vent to crankcase installation. See **Flow Rate Test Chart** for maximum pressure.

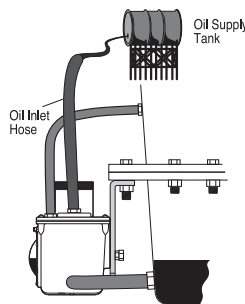

Verify that hose clamps are tight and all connections are secure before filling the oil supply tank.

Ensure no oil leaks are present.

Close the oil supply tank shut-off valve before filling tank.

3. Verify the oil supply tank is clean and dry and the shut-off valve is closed. Also, verify all hoses and clamps are tight. Fill the tank with CLEAN oil.
4. Once the oil supply tank is full, open the shut-off valve.
5. Make the proper electrical connections for the application. Refer to section **Models, Wiring and Operation Ranges of Switches**.

Models, Wiring and Operating Ranges of Switches

- LM300: Level Maintainer only (no switches).
- LM301: Low switch contacts for low level shutdown or alarm. Four wires, SPDT.
- LM302: Two switches for low and high level shutdown or alarm. Four wires, DPST, wired N.O. in normal operating ranges.
- LM303: Two switches for low and high level shutdown or alarm. Four wires, DPST, wired N.C. in normal operating ranges.
- LM304: Two switches. Alarm before shutdown on low level and shutdown on low-low level. Four wires, DPST, wired N.O. in normal operating ranges.
- LM305: Two switches. Alarm before shutdown on low level and shutdown on low-low level. Four wires, DPST, wired N.C. in normal operating ranges.

Wiring Schematics

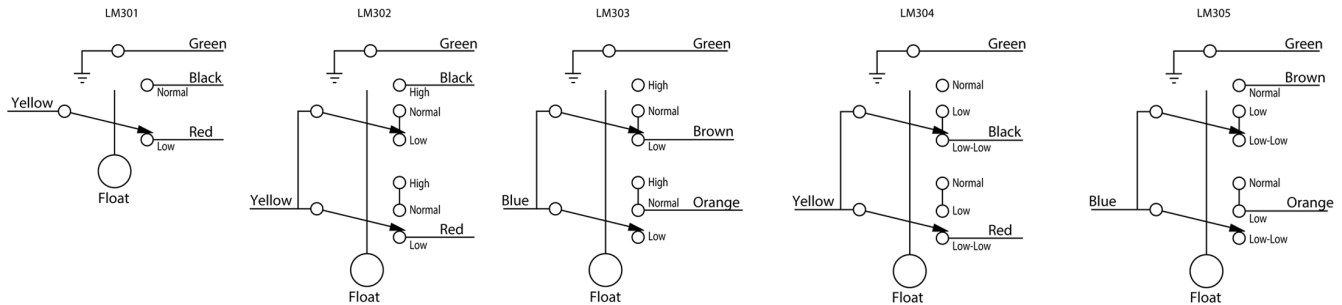

Operating Ranges

The illustrations show the dials and the operating ranges of the switches. If levels are within the designated zones, the switch will activate. Notice that a switch is capable of activating approximately 3/8 in. (10 mm) from the top of the high zone and 3/8 in. (10 mm) from the bottom of the low zone. The dial of models LM304 and LM305 shows that if the level continues to drop into the low-low zone, a shutdown will occur.

NOTE: Color zones on dial face show approximate normal operating zones. Actual conditions may vary depending upon operating characteristics of the engine. Placement of the Level Maintainer according to the installation instructions will compensate for these conditions.

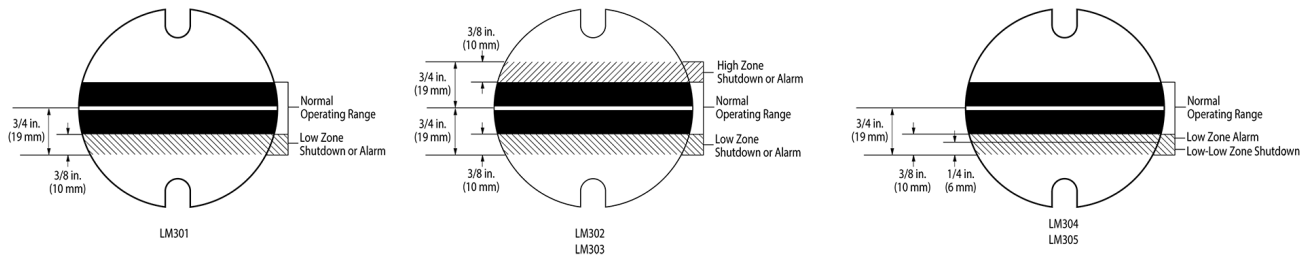

Switch Test (Switch Models Only)

Perform the Switch Test to ensure all shutdown and alarm functions are working properly.

1. Unscrew the protective boot from test knob. IMPORTANT: Always replace boot after testing.
2. Turn the test knob 1/4 turn to the right (clockwise), for low test indication.
3. Turn the test knob 1/4 turn to the left (counterclockwise), for high test indication. DO NOT FORCE THE TEST KNOB TO TURN.

NOTES:

After the engine shuts down, you will notice that the oil in the sight gauge glass will rise above normal running level, possibly showing an overfill condition. This is a result of drain-back to the engine crankcase, and it is normal.

Therefore, on models LM302 and LM303 it may be necessary to wire the high level shutdowns into a class B or C (bypass until first time safe) lockout, so as to allow a permissive start.

After the engine is re-started the level will pull down to the normal running level and the shutdown features will be active.

A modulating valve (Thumb-Valve™) in the Level Maintaining Models will allow oil usage to be made-up continuously during operation.

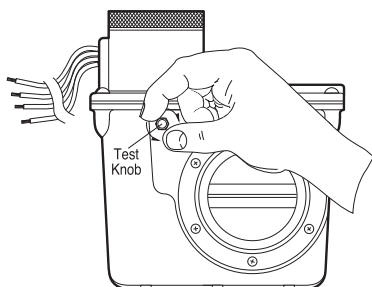

Specifications

Case/Cover: Die cast aluminum

Switch Housing: Aluminum

Approval Rating:

LM301 thru LM305 : CSA certified^{††} for non hazardous locations. Enclosure Type 4 certified

LM301-EX thru LM305-EX: CSA certified^{††} for Class I, Groups C and D; Class II, Groups F and G hazardous locations. Enclosure Type 4 certified

Floater: Rigid polyurethane foam. Polyurethane coated

Maximum Ambient Temperature: 250° F (121° C)

Oil Inlet Connection: Top entry 1/2-14 NPT with built-in filter screen (removable for cleaning)

Inlet Orifices:

Standard: 1/4 in. (6 mm)

Available: 1/8 in. (3 mm) and 1/16 in. (1.5 mm)

Wire (switch models): 18 AWG x 13 in. (1.0 mm² x 330 mm)

Maximum Inlet Pressure (MIP):

15 ft. oil (4.6 m oil) with 1/4 in. (6 mm) orifice

30 psi (207 kPa) [2.07 bar] with 1/8 in. (3 mm) orifice

70 psi (483 kPa) [4.83 bar] with 1/16 in. (1.5 mm) orifice

Maximum Case Pressure (MCP): 15 psi (103 kPa) [1.03 bar]

Orifice Seal: Buna-N Thumb-Valve™

Switch Contact: Silver, SPDT snap acting, 10 A @ 125, 250 VAC; 10 A @ 30 VDC (1 only for low level; 2 only for high & low; or 2 only for low with alarm before shutdown)

Outlet Connection: 3/4-14 NPT left side, right side, and bottom

Crankcase Balance Vent Fitting: 1/2-14 NPT

Mounting: Accepts Murphy's mounting Pipe and Universal Brackets

Lens: Clear Frog Eye non-staining, high impact, high temperature nylon; UV and heat stabilized

Glass Lens: Available on LM301 and LM301-EX models. Specify GL as part of model number when ordering

Dial: High visibility, white background with green and white index lines for normal level indication

Test Knob: Rotate to test switch operation. Turn clockwise for low level test and turn counterclockwise for high level test

Flow Rate Test: Using SAE 30 @ 32° F (0° C)

Flow Rate Test Chart (Using SAE 30 @ 32° F (0° C))

Orifice Diameter	Head Pressure	Flow Rates
1/4 in. (6 mm) (Standard Size)	4 ft. oil - 15 ft. oil (1.2 m oil - 4.6 m oil)	4.7 GPH - 31.0 GPH (17.8 LPH - 117.3 LPH)
1/8 in. (3 mm)	10 psig - 30 psig (68.9 kPa - 207 kPa) [.69 - 2.07 bar]	16.9 GPH - 32.1 GPH (63.7 LPH - 121.5 LPH)
1/16 in. (1.5 mm)	30 psig - 70 psig (207 kPa - 483 kPa) [2.07 - 4.83 bar]	6.6 GPH - 14.8 GPH (24.8 LPH - 56.1 LPH)

NOTE: Friction loss due to piping NOT considered.

^{††}CSA certified with switch contacts rated at 10 A @ 250 VAC (standard).

FW MURPHY PRODUCTION CONTROLS

SALES, SERVICES & ACCOUNTING
4646 S. HARVARD AVE.
TULSA, OK 74135

CONTROL SYSTEMS & SERVICES
105 RANDON DYER ROAD
ROSENBERG, TX 77471

MANUFACTURING
5757 FARINON DRIVE
SAN ANTONIO, TX 78249

DOMESTIC SALES & SUPPORT

FW MURPHY PRODUCTS
PHONE: 918 957 1000
EMAIL: INFO@FWMURPHY.COM
WWW.FWMURPHY.COM

FW MURPHY CONTROL SYSTEMS & SERVICES
PHONE: 281 633 4500
EMAIL: CSS-SOLUTIONS@FWMURPHY.COM

INTERNATIONAL SALES & SUPPORT

CHINA
PHONE: +86 571 8788 6060
EMAIL: INTERNATIONAL@FWMURPHY.COM

LATIN AMERICA & CARIBBEAN
PHONE: +1 918 770 8775
EMAIL: INTERNATIONAL@FWMURPHY.COM

SOUTH KOREA
PHONE: +82 70 7951 4100
EMAIL: INTERNATIONAL@FWMURPHY.COM



FM 668576 (San Antonio, TX - USA)
FM 668933 (Rosenberg, TX - USA)



FM 523851 (China) TS 589322 (China)