

Universal Small Instrument Panels

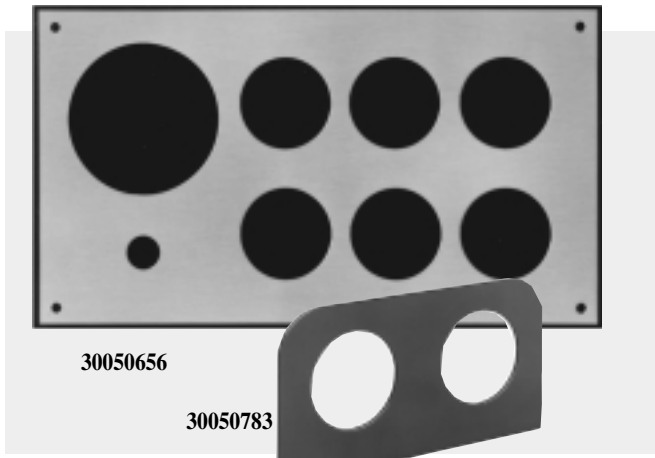

- Marine Engines
- Mobile Equipment
- Drilling Engines
- Auxiliary Generators
- Stationary Power Units

Description

Murphy universal panels are compact and easy to install and are available in a variety of sizes and configurations for all types of applications. These panels are durable and corrosion resistant. All are made of 16 gauge, 304 stainless steel. You specify the instrumentation you want to suit your equipment. Panels can be ordered with instrumentation installed and prewired. Design and size of the panels give maximum flexibility in design and application to your instrument cluster.

Panels 30050782, 30050783 and 30050784 can accommodate reliable 2 in. (51 mm) dial SWICHGAGE® instruments. Typical applications for these panels are marine, mobile and stationary engines.

Panel 30050782 has one 2-1/16 in. (52 mm) diameter hole.

Panel 30050783 has two 2-1/16 in. (52 mm) diameter holes.

Panel 30050784 has three 2-1/16 in. (52 mm) diameter holes.

Panels 30050527 and 30050656 are typically mounted in the dash of small boats. These panels can accommodate 2 in. (51 mm) dial SWICHGAGE® instruments and 3 in. (76 mm) dial tachometer.

Panel 30050527 hole configurations:

- One 3-7/16 in. (87 mm) diameter hole.
- Four 2-1/16 in. (52 mm) diameter holes.
- One 3/4 in. (19 mm) diameter hole.

Panel 30050656 hole configurations:

- One 3-7/16 in. (87 mm) diameter hole.
- Six 2-1/16 inch diameter holes.
- One 3/4 in. (19 mm) diameter hole.

SWICHGAGE® Instruments

Adding SWICHGAGE® instruments to your panel provides engine protection. A SWICHGAGE® is two instruments in one: (1) an accurate indicating gage with (2) a built-in, adjustable limit switch. The limit switch can operate Murphy ST Series SELECTRONIC® TATTLETALE® annunciators or be incorporated into existing engine shutdown or alarm systems. See Murphy

General Catalog for more information on SWICHGAGE® instruments and SELECTRONIC® TATTLETALE® annunciators.

How to Order

Specify panel part number and instrumentation when ordering.

30050527
30050656
30050782
30050783
30050784

Warranty

A two-year limited warranty on materials and workmanship is given with this Murphy product. Details are available on request and are packed with each unit.



Typical twin engine installation using two 30050527 panels

30050527

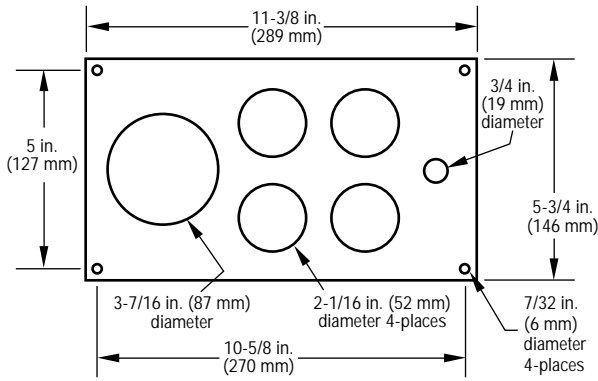

30050656

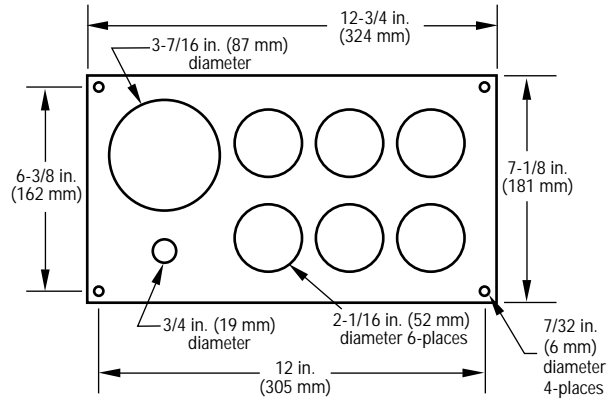

30050782

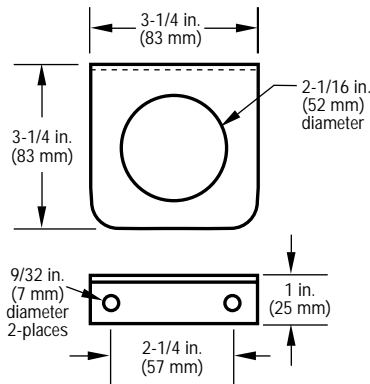

30050783

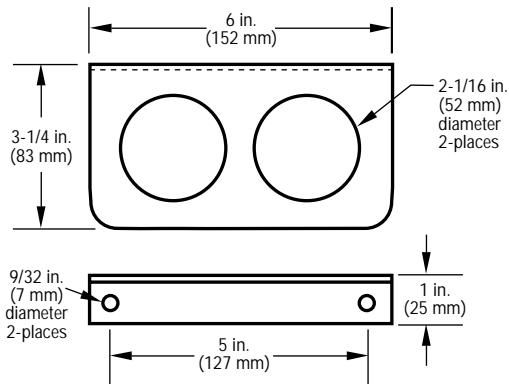

30050784

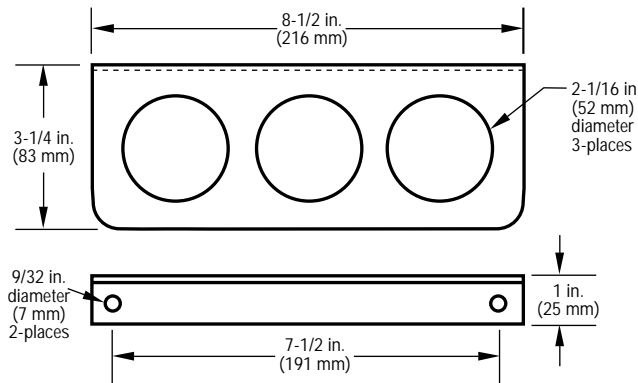

In order to consistently bring you the highest quality, full featured products, we reserve the right to change our specifications and designs at any time.

FRANK W. MURPHY MANUFACTURER P.O. Box 470248; Tulsa, Oklahoma 74147; USA tel. (918) 627-3550 fax (918) 664-6146 e-mail sales@fwmurphy.com http://www.fwmurphy.com



■ **FRANK W. MURPHY SOUTHERN DIVISION**
P.O. Box 1819; Rosenberg, Texas 77471; USA
tel. (281) 342-0297 fax (281) 341-6006
e-mail sales@fwmurphy.com

■ **MURPHY DE MEXICO, S.A. DE C.V.**
Blvd. Antonio Rocha Cordero 300, Fracción del Aguaje
San Luis Potosí, S.L.P.; México 78384
tel. +52-48-206264 fax +52-48-206336
e-mail murmexsl@sanluis.podernet.com.mx

■ **MURPHY SWITCH OF CALIFORNIA**
41343 12th Street West
Palmdale, California 93551-1442; USA
tel. (661) 272-4700 fax (661) 947-7570
e-mail sales@murphyswitch.com
http://www.murphyswitch.com



USA-ISO 9001 FM 28221
UK-ISO 9002 FM 29422

■ **FRANK W. MURPHY, LTD.**
Church Rd.; Laverstock, Salisbury SP1 1QZ; U.K.
tel. +44 1722 410055 fax +44 1722 410088
e-mail sales@fwmurphy.co.uk
http://www.fwmurphy.co.uk

■ **FRANK W. MURPHY PTE., LTD.**
No. 2 Tuas South Street 2,
Sprintecs Bldg., #02-01/02
Singapore 638042
tel. +65 863-1398 fax +65 863-0208
e-mail fwmurphy@fwmurphy.com.sg

■ **MACQUARRIE CORPORATION**
1620 Hume Highway;
Campbellfield, Vic 3061; Australia
tel. +61 3 9358-5555 fax +61 3 9358-5558
e-mail murphy@macquarrie.com.au